

Service Manual

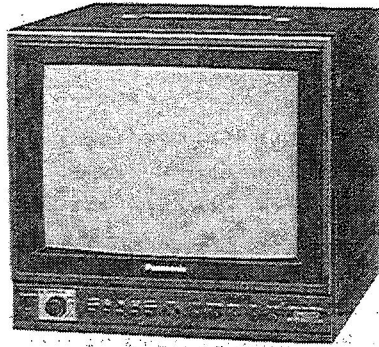

Color Video Monitor
BT-S1000N
Chassis No. KMX-F104A

Retain on file with CT-1030M/CT-1030MC Main Manual.

Model BT-S1000N is the same as models CT-1030M/CT-1030MC except specified herein. For complete service informations, refer to above Service Manual (ORDER NO. KME8611062C1).

The service technician is required to read and follow the "Safety Precautions" and "Important Safety Notice" in this service manual.

Specifications

Power Input:	120 volts, AC, 50/60 Hz 12 volt DC, 5A		Automatic degaussing
Power Consumption:	AC-46W (Average), DC-46W (Average)		Automatic Voltage Regulator
Video Input (Bridging):	1.0Vp-p \pm 10% High or 75 Ω automatic BNC type bridging and 8-pin connectors	Quality Engineering : Feature	Automatic Beam Limiter
Audio Input (Bridging):	RCA type bridging and 8-pin connectors		Automatic Color Control
External Sync Input: (Bridging)	2.0 ~ 4.0Vp-p, negative composite High or 75 Ω automatic BNC type bridging connectors		Mode Selector Switch (VTR/LINE, Underscan, Pulse Cross, Blue Only, Comb/Trap)
Semiconductors:	43 transistors 66 diodes 1 posistor 9 ICs		Sync Switch
Anode Voltage:	23.5 kV \pm 1 kV (at zero beam current)		Vertical Centering Control
Sound Output:	1.0 watt (10% distortion) 1.2 watts maximum		Horizontal Centering Control
Speaker:	2-1/2 inches Round Type Voice Coil 16 Ω		Vertical Size Control (Normal/Underscan Modes)
Automatic Circuits:	Automatic Impedance Switch Automatic Frequency and Phase Control Horizontal Automatic Frequency Control		Horizontal Size Control (Underscan Mode)
			Vertical Position Control (Pulse Cross Mode)
			Horizontal Position Control (Pulse Cross Mode)
			AC/DC Operation
		Picture Tube:	A26JGZ31X 52 Square inches 10 inches measured diagonally 90° deflection, In-Line
		Dimensions:	Height: 10-13/16 inches (275 mm) Width: 11-3/16 inches (284 mm) Depth: 12-11/16 inches (322 mm)
		Weight:	19-1/4 lbs. (9.2 kg)

Specifications are subject to change without notice.
Weight and dimensions shown are approximate.

Panasonic[®]

Panasonic Industrial Company
Division of Matsushita Electric
Corporation of America
One Panasonic Way Secaucus,
New Jersey 07094

Panasonic Hawaii Inc.
91-238 Kauh St. Ewa Beach
P.O. Box 774
Honolulu, Hawaii 96808-0774

Panasonic Sales Company,
Division of Matsushita Electric
of Puerto Rico, Inc.
Ave. 65 De Infanteria, KM 9.7
Victoria Industrial Park
Carolina, Puerto Rico 00630

Specifications are subject to change without notice.

CONTENTS

SAFETY PRECAUTIONS	2
MAJOR DIFFERENCES BETWEEN CT-1030M AND BT-S1000N	4
BASIC OPERATING INSTRUCTIONS	5
CONNECTION OF VIDEO/AUDIO TERMINALS	6
FIELD ADJUSTMENTS	9
GENERAL ALIGNMENTS	11
CIRCUIT EXPLANATION	12
CONDUCTOR VIEWS	13
SCHEMATIC DIAGRAM	16
EXPLODED VIEWS	18
REPLACEMENT PARTS LIST	19

THIS MODEL COMPLIES WITH DHHS RULES 21 CFR SUBCHAPTER J APPLICABLE AT DATE OF MANUFACTURE.

IMPORTANT SAFETY NOTICE

There are special components used in Panasonic Video Monitor sets which are important for safety. These parts are shaded on the schematic diagram and on the replacement parts list. It is essential that these critical parts should be replaced with manufacturer's specified parts to prevent X-RADIATION, shock, fire, or other hazards. Do not modify the original design without permission of Panasonic Industrial Company.

ABBREVIATIONS USED IN THIS MANUAL

ABL	Automatic Beam Limiter	AVR	Automatic Voltage Regulator
APC	Automatic Phase Control	CRT	Cathode Ray Tube
DY	Deflection Yoke	FBT	Flyback Transformer
OTL	Output Transformerless	HAFC	Horizontal Automatic Frequency Control
SEPP	Single Ended Push-Pull Circuit	ACC	Automatic Color Control

SAFETY PRECAUTIONS**GENERAL GUIDELINES**

1. It is advisable to insert an isolation transformer in the power line and AC supply before servicing a hot chassis.
2. When servicing, observe the original lead dress, especially the lead dress in the high voltage circuits. If a short circuit is found, replace all parts which have been overheated or damaged by the short circuit.
3. After servicing, see to it that all the protective devices such as insulation barriers, insulation papers, shields, and isolation C-R combinations, are properly installed.
4. Before turning the monitor on, measure the resistance between B+ line and chassis ground. Connect \ominus side of an ohmmeter to the B+ lines, and \oplus side to chassis ground. Each line should have more resistance than specified, as follows:

B+ Line	Minimum Resistance
121V	56k Ω
27V	28k Ω
15V	100k Ω
12V	280 Ω

5. When the monitor is not to be used for a long period of time, unplug the power cord from the AC outlet.
6. Potentials, as high as 23.5 kV are present when this monitor is in operation. Operation of the monitor without the rear cover involves the danger of a shock hazard from the monitor power supply. Servicing should not be attempted by anyone who is not thoroughly familiar with the precautions necessary when working on high voltage equipment. Always discharge the anode of the picture tube to the monitor chassis before handling the tube.
7. After servicing, make the following leakage current checks to prevent the customer from being exposed to shock hazards.

LEAKAGE CURRENT COLD CHECK

1. Unplug the AC cord and connect a jumper between the two prongs on the plug.
2. Turn on the monitor's power switch.
3. Measure the resistance value, with an ohmmeter, between the jumpered AC plug and each exposed metallic cabinet part on the monitor, such as screwheads, connectors, control shafts, handle bracket, etc.
When the exposed metallic part has a return path to the chassis, the reading should be between 240 kΩ and 5.2MΩ.
When the exposed metal does not have a return path to the chassis, the reading must be ∞.

LEAKAGE CURRENT HOT CHECK (See figure 1.)

1. Plug the AC cord directly into the AC outlet. DO NOT use an isolation transformer for this check.
2. Connect a 1.5 kΩ, 10 watts resistor, in parallel with a 0.15 μF capacitor, between each exposed metallic part on the set and a good earth ground such as a water pipe, as shown in figure 1.
3. Use an AC voltmeter, with 1000 ohms/volt or more sensitivity, to measure the potential across the resistor.
4. Check each exposed metallic part, and measure the voltage at each point.
5. Reverse the AC plug in the AC outlet and repeat each of the above measurements.
6. The potential at any point should not exceed 0.75 volts RMS. A leakage current tester (Simpson Model 229 or equivalent) may be used to make the hot check. Leakage current must not exceed 1/2 milliamp. In case a measurement is outside of the limits specified, there is a possibility of a shock hazard, and the monitor should be repaired and rechecked before it is returned to the customer.

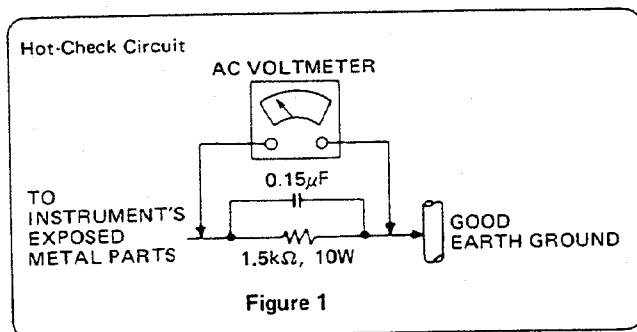

X-RADIATION

WARNING: 1. The potential source of X-Radiation in TV sets is the High Voltage section and the picture tube.

2. When using a picture tube test jig for service, make sure that the jig is capable of handling 24.5 kV without causing X-Radiation.

Note: It is important to use an accurate, periodically calibrated high voltage meter.

1. Turn Brightness and Contrast controls fully counter-clockwise.
2. Set SERVICE switch to SERVICE position.
3. Measure the high voltage. The high voltage meter (electrostatic type) reading should indicate 23.5 kV ± 1.0 kV. If the meter indication is out of tolerance, immediate service and correction is required to prevent the possibility of premature component failure.
4. To prevent an X-Radiation possibility, it is essential to use the specified picture tube.
5. To prevent exposure to X-Radiation, the picture tube shield must be kept in place with power applied to the set.

HORIZONTAL OSC. DISABLE CIRCUIT TEST

SERVICE WARNING: This test must be made as a final check before the monitor is returned to the customer after repairs are made.

1. With rear cover removed, supply nominal 120V AC to the monitor and turn on power switch.
2. Adjust customer controls to normal position.
3. Short TP92 and TP93 on main PCB with a jumper wire. Confirm that the picture becomes dark and goes out of horizontal sync.
4. If the test fails, Horizontal Osc. Disable Circuit is not operating and must be repaired. Refer to the Horizontal Osc. Disable Circuit Repair Procedure.

HORIZONTAL OSC. DISABLE CIRCUIT REPAIR PROCEDURE

- 1) Connect a DC voltmeter between the cathode of D510 and chassis ground of the main circuit board. If approximately 19V is not present on the cathode of D510, find the cause. Check R529, D510 and C525.
- 2) Connect a DC voltmeter between the cathode of D512 and chassis ground of the main circuit board. If approximately 10V is not present on the cathode of D512, find the cause. Check R524, R523 and D511.
- 3) Repeat step 2) procedure. If approximately 10V is present on the cathode, check D512, R522, Q504, R521 and IC401.
- 4) Carefully check above specified parts, and related circuits and parts. When the circuit is repaired, try the Horizontal Osc. Disable Circuit Test again.

MAJOR DIFFERENCES BETWEEN CT-1030M AND BT-S1000N

Items	CT-1030M	BT-S1000N
DC Operation	—	Available
Circuit Board-B	—	TNP100306ZA
DC Power Socket	—	TJS169410
Power/Volume Control	EVVVGU5F25B14	EVVVGU8F25B14
Underscan Circuit	—	Available
Pulse Cross Circuit	—	Available
Circuit Board-X	—	TNP100312ZA
Blue Only Circuit	—	Available
Terminal Board	TJB13610	TJB13611
External Sync In/Out	—	Available
External Sync Switch	—	Available
Circuit Board-A	TNP190018ZA	TNP190018CD
Circuit Board-C	TNP100307ZA	TNP100307CD
Circuit Board-L	TNP100311ZA	TNP100311CD
Instruction Bag	TQB511101	TQB511103
Front Cabinet	TKE1312A01	TKE1312A02
Back Cabinet	TKU136700-1	TKU136701-1
Packing Case	TPC1310601	TPC1310701

BASIC OPERATING INSTRUCTIONS

CONTROL LOCATIONS [Front View]

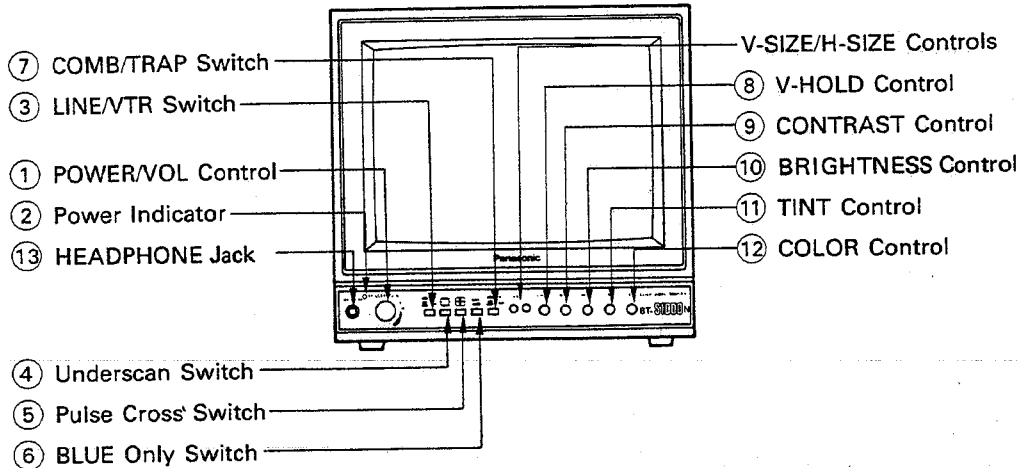

CONTROLS AND THEIR FUNCTIONS

Note: V-HOLD, CONTRAST, BRIGHTNESS, TINT and COLOR controls are equipped with "push-lock" switches. In the locked position, the controls are protected from being moved, and in the projected position, they can be easily touched up.

- ① **POWER/VOL Control**
 1. Turn clockwise to turn the monitor on.
Turn counterclockwise to turn the monitor off.
 2. Adjust this control for the appropriate audio level.
- ② **Power Indicator**

The Power Indicator will light when the monitor is turned on.
- ③ **LINE/VTR Switch**

LINE: Receives video and audio signal from the VIDEO IN and AUDIO IN terminals.
VTR: Receives video and audio signal from the VTR terminal.
- ④ **Underscan Switch ()**

Decreases the overall picture size to allow the corners to be seen.
- ⑤ **Pulse Cross Switch ()**

Receives cross pulse to allow vertical and horizontal syncs to be seen in the picture.
- ⑥ **BLUE Only Switch (BLUE)**

Defeats the red and green signals. This feature is used for monitor balancing with the SMPTE color bar signal.
- ⑦ **COMB/TRAP Switch**

Push the COMB/TRAP Switch for trap filter function. Push again for comb filter function.
- ⑧ **V-HOLD Control**

Adjust the V-HOLD control if the picture rolls up or down.
- ⑨ **CONTRAST Control**

Adjust the contrast level for proper overall contrast. There is a click position for normal level.
- ⑩ **BRIGHTNESS Control**

Adjust Brightness level for proper overall picture brightness. There is a click position for normal level.
- ⑪ **TINT Control**

Adjust the Tint control for proper chroma phase of flesh tones.
- ⑫ **COLOR Control**

Adjust the Color control to set the chroma (saturation) level.
- ⑬ **HEADPHONE Jack**

Audio may be monitored by the headphones using this jack (monaural sound).

CONNECTION OF VIDEO/AUDIO TERMINALS

TERMINAL BOARD ON REAR COVER

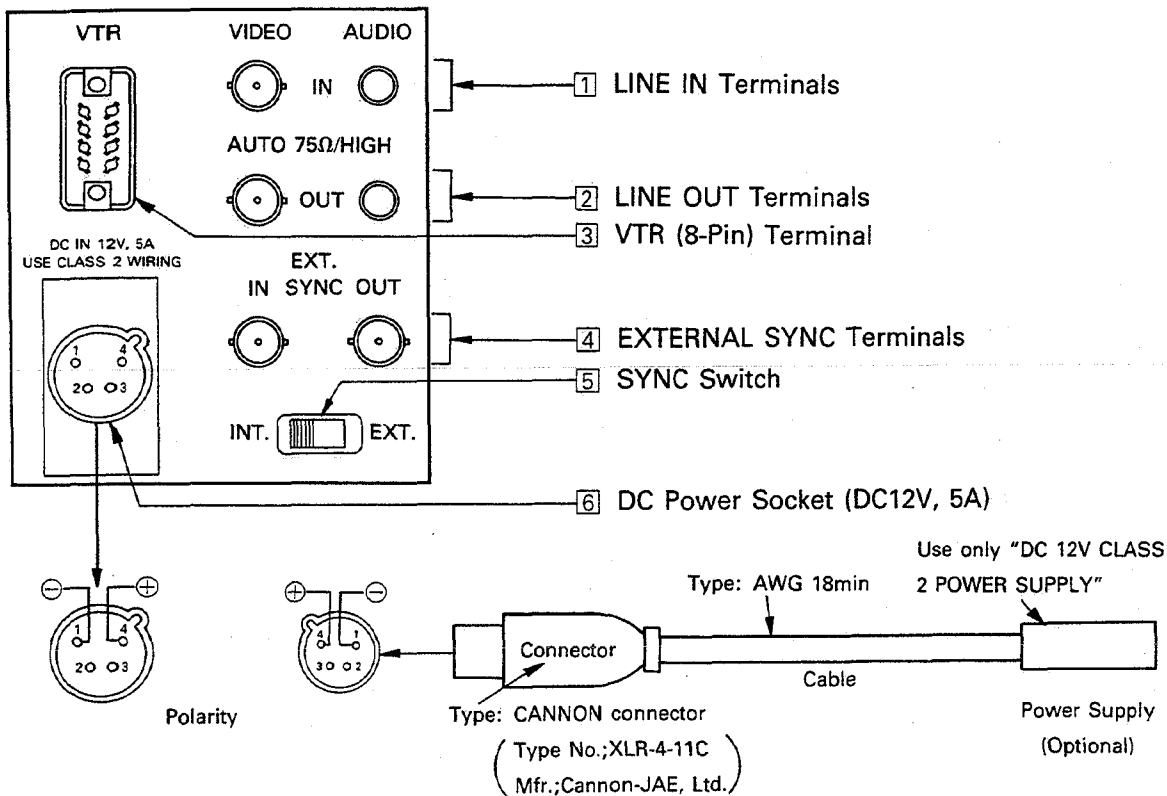

SIGNAL LEVEL AND TERMINAL IMPEDANCE

Terminal	Item	Level	Impedance	Remarks
VIDEO	INPUT	1Vp-p (0.7Vp-p)	Auto 75Ω/High	Includes sync signal. (Does not include sync signal.)
	OUTPUT	1Vp-p (0.7Vp-p)	Auto 75Ω/High	
AUDIO	INPUT	-6dB	10 kΩ	1Vrms=0dB at 400Hz
	OUTPUT	-6dB	10 kΩ	
AUDIO/VIDEO	VTR	1Vp-p	75Ω	Video and audio signal
		1.0Vrms	20 kΩ	
EXT. SYNC	INPUT	2~4Vp-p	Auto 75Ω/High	Negative vertical and horizontal sync
	OUTPUT	2~4Vp-p	Auto 75Ω/High	

TERMINALS AND THEIR FUNCTIONS

1 LINE IN Terminals

Receive video and audio signals from outside source. This signal is available at the LINE OUT (Throughout) terminals.

2 LINE OUT Terminals

Whichever signal at the input will be available at this terminal (Throughout).

3 VTR (8-Pin) Terminal

Receives video and audio signals from VTR, VCR or video disc which has an 8-Pin Connector.

4 EXTERNAL SYNC Terminals

IN When a non-composite video signal is connected to the monitor, it will be necessary to connect an external composite sync signal to the monitor.
OUT... Through out the sync signal.

5 SYNC Switch

Set the SYNC Switch to EXT. position when connecting an external composite sync signal to the monitor.

6 DC Power Socket

When the monitor is operated with DC power source, connect DC 12V 5A power supply to this socket by a CANNON type connector. The wiring for power supply should be Class 2 by National Electrical Code.

Note: 1. The video and the external sync input/output terminals are equipped with "Automatic Termination Switch". If only input signal is applied, they are terminated by 75 ohm, and if both input/output signals applied, they are opened to high impedance.

2. It is possible to connect up to 10 monitors in series by looping through the LINE IN and LINE OUT terminals. There may be a possibility of a brightness reduction or interference if more than 10 units are connected. Please carefully confirm that these problems do not exist with the units before connection.

3. 1) This monitor provides an ADDP (Automatic Deep-Discharge Protector) circuit, which prevents the battery from being deep-discharged and the battery life being shortened.
2) When the output voltage of the battery connected to the set becomes lower than specified, the ADDP circuit operates and the set automatically goes off.
3) When the set goes off by the ADDP circuit, immediately turn the POWER/VOL Switch to "OFF" position and charge the battery.

BT-S1000N

CONNECTION WITH OTHER EQUIPMENTS

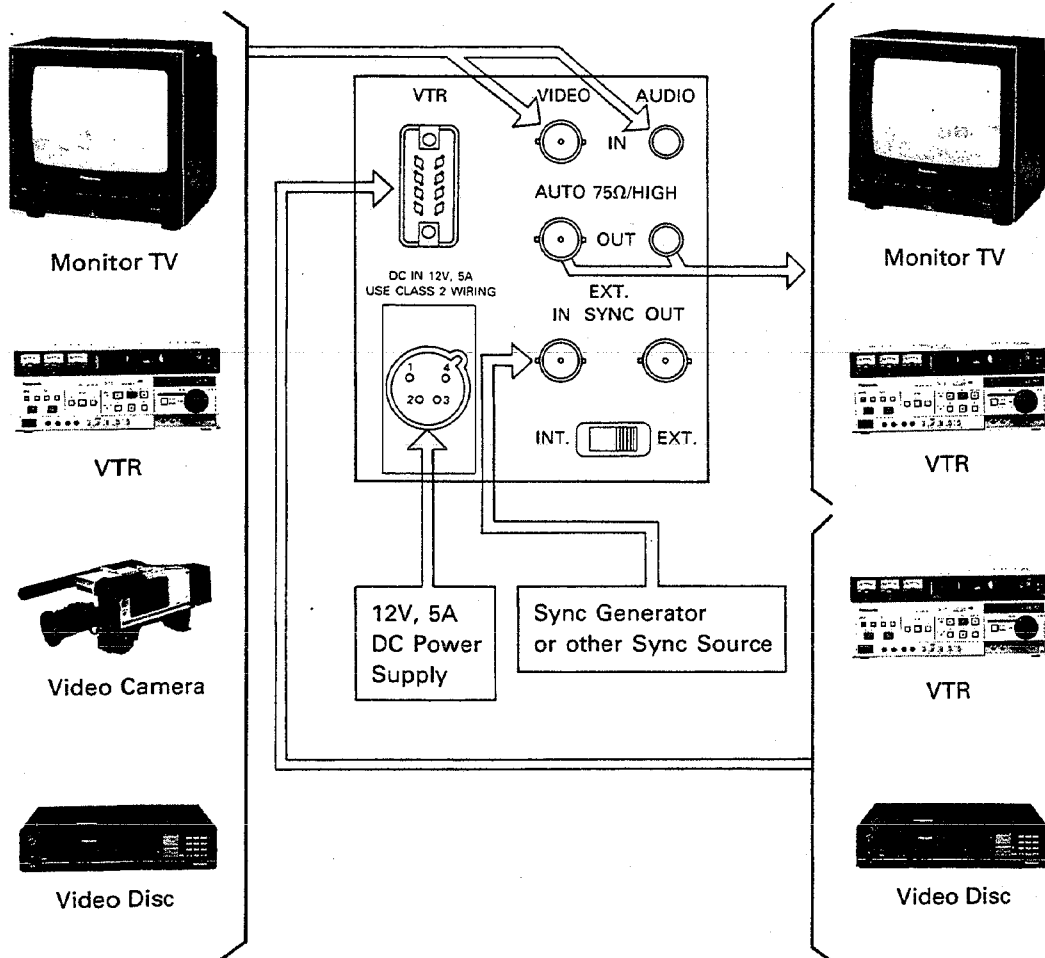

FIELD ADJUSTMENTS

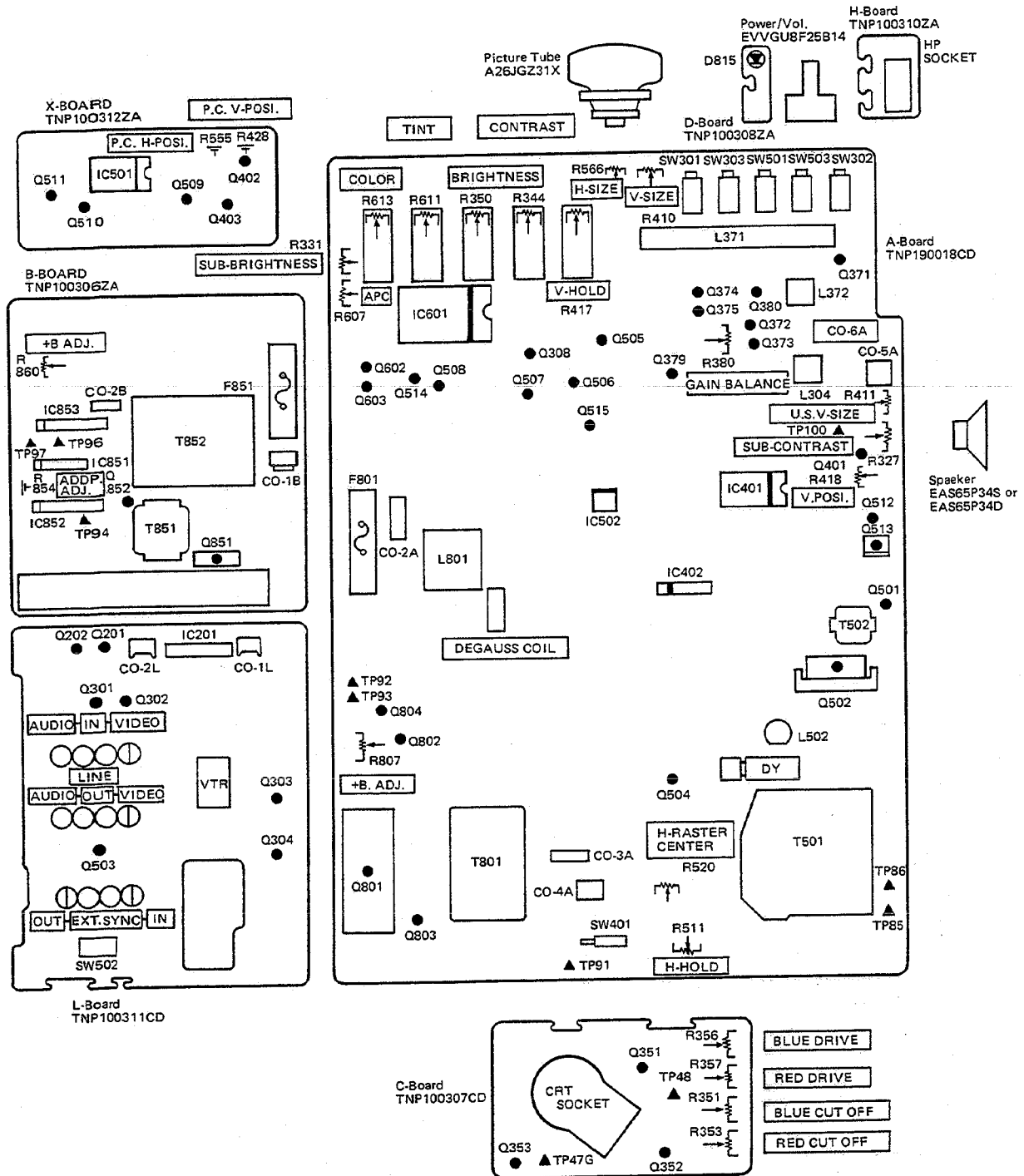

Figure 2

A. SERVICING ADJUSTMENTS
VERTICAL SIZE ADJUSTMENT

Adjust V-Size control (R410) until picture becomes symmetrical from top to bottom.

HORIZONTAL SIZE ADJUSTMENT

Adjust H-Size control (R566) until the horizontal picture size is proper on the screen.

HORIZONTAL HOLD ADJUSTMENT

Adjust H-Hold control (R511) and set it at the point where horizontal movement (diagonal lines) stops.

FOCUS ADJUSTMENT

Adjust Focus control on FBT to obtain the sharpest and clearest picture.

B. INTERNAL ADJUSTMENTS

When measuring voltage with a VTVM, be sure to use the test points located on the conductor side of the circuit boards.

VERTICAL POSITION ADJUSTMENT

Adjust V-Position control (R418) until picture becomes vertical center.

H-RASTER CENTER ADJUSTMENT

Adjust H-Raster Center control (R520) until picture becomes centered horizontally.

UNDERSCAN V. SIZE ADJUSTMENT

1. Apply a monoscope pattern to the monitor.
2. Push Underscan switch on the front panel.
3. Adjust U.S. V-Size control (R411) until picture height becomes $4\text{ mm} \pm 1\text{ mm}$ shorter than picture tube screen at top and bottom as shown in figure 3.
4. If the picture is shifted upper or lower, adjust V-Position control (R418).

UNDERSCAN H. SIZE ADJUSTMENT

1. Apply a monoscope pattern to the monitor.
2. Push Underscan switch on the front panel.
3. Adjust H-Size control (R566) until picture width becomes $6\text{ mm} \pm 1\text{ mm}$ shorter than picture tube screen at both sides as shown in figure 3.
4. If the picture is shifted left or right, adjust H-Raster Center control (R520).

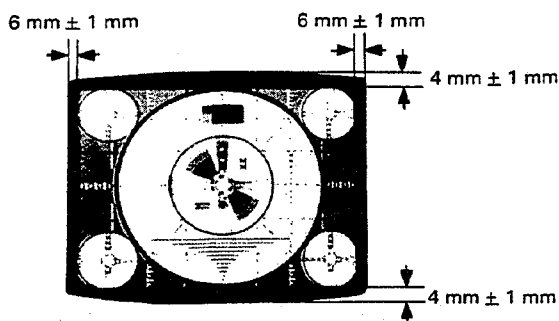
**Figure 3****PULSE CROSS V-POSITION ADJUSTMENT**

1. Apply a monoscope pattern to the monitor.
2. Push Pulse Cross switch on the front panel.
3. Adjust P.C. V-Position control (R428) until horizontal blanking line becomes at the vertical center on picture tube screen. (See figure 4.)

PULSE CROSS H-POSITION ADJUSTMENT

1. Apply a monoscope pattern to the monitor.
2. Push Pulse Cross switch on the front panel.
3. Adjust P.C. H-Position control (R555) until the length between left screen edge and vertical blanking line becomes approximately 35 mm. (See figure 4.)

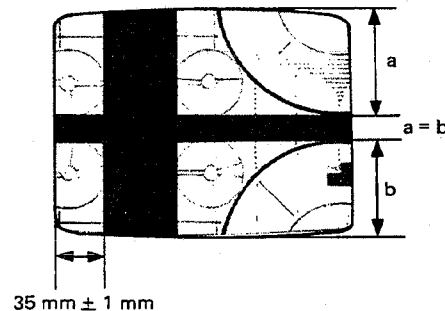
**Figure 4****SUB-BRIGHTNESS CONTROL ADJUSTMENT**

This is factory adjusted. Usually no further adjustment is required in the field. However, when the A-Board, C-Board or CRT is replaced, the following adjustment is necessary:

1. Apply a cross hatch pattern signal.
2. Set Brightness (R350) and Contrast (R344) controls at their click position.
3. Connect the DC voltmeter between TP85 and TP86 (positive lead of the voltmeter to TP85 and negative lead to TP86).
4. Adjust Sub-Brightness control (R331) so that the reading of the voltmeter becomes approximately 5.5V for proper picture brightness.

Note: For this adjustment NTSC Pattern Generator, model LCG-396 manufactured by Leader Electronics Corp. (Japan) is recommended.

GENERAL ALIGNMENTS

+121V ALIGNMENT

Preparation (See figure 5.)

1. Connect a 12V (10A) DC power supply between TP93 and TP95 (negative to TP95) on B-Board and operate the receiver more than 20 minutes.
2. Connect a digital multi-meter between TP93 and TP95 (negative to TP95).
3. Set the DC power supply so that the reading of the meter becomes $11.5V \pm 0.1V$ at TP93.
4. Then connect the digital multi-meter between TP92 and TP95 (negative to TP95).

Alignment Procedure

1. Apply a black and white signal under normal reception conditions.
2. Set Brightness and Contrast controls fully counter-clockwise, volume to minimum and Service Switch to SERVICE position.
3. Adjust R860 (+B ADJ.) to set the output voltage to $121V \pm 0.5V$ at TP92.

ADDP ALIGNMENT

Preparation (See figure 5.)

1. Connect a 12V (10A) DC power supply between TP93 and TP95 (negative to TP95) on B-Board and operate the receiver more than 20 minutes.

Alignment Procedure

12V ADDP adjustment

1. Apply a black and white signal under normal reception conditions.
2. Set Brightness and Contrast controls to maximum and volume to minimum.
3. Turn 12V ADDP control (R854) fully counterclockwise.
4. Set the DC power supply so that the reading of the multi-meter becomes 10.3V at TP93.
5. Then connect the multi-meter between TP94 and TP95 (negative to TP95).

2. Connect a digital multi-meter between TP93 and TP95 (negative to TP95).

6. Slowly turn the ADDP control clockwise and stop where the reading of the multi-meter changes from 0.06V to 2.5V.
7. Confirm that the voltage at TP94 reduces to 0.06V when the DC voltage at TP93 is 10.4V.
8. Connect a 1.2k ohm resistor between TP96 and TP97, and confirm that the picture disappears (ADDP operates) a few seconds after the voltage at TP93 is reduced to 10.2V.

Note: Without resistor, delayed ADDP circuit needs about 150 seconds to cut off the converter circuit after input voltage becomes equal to or less than 10.2V.

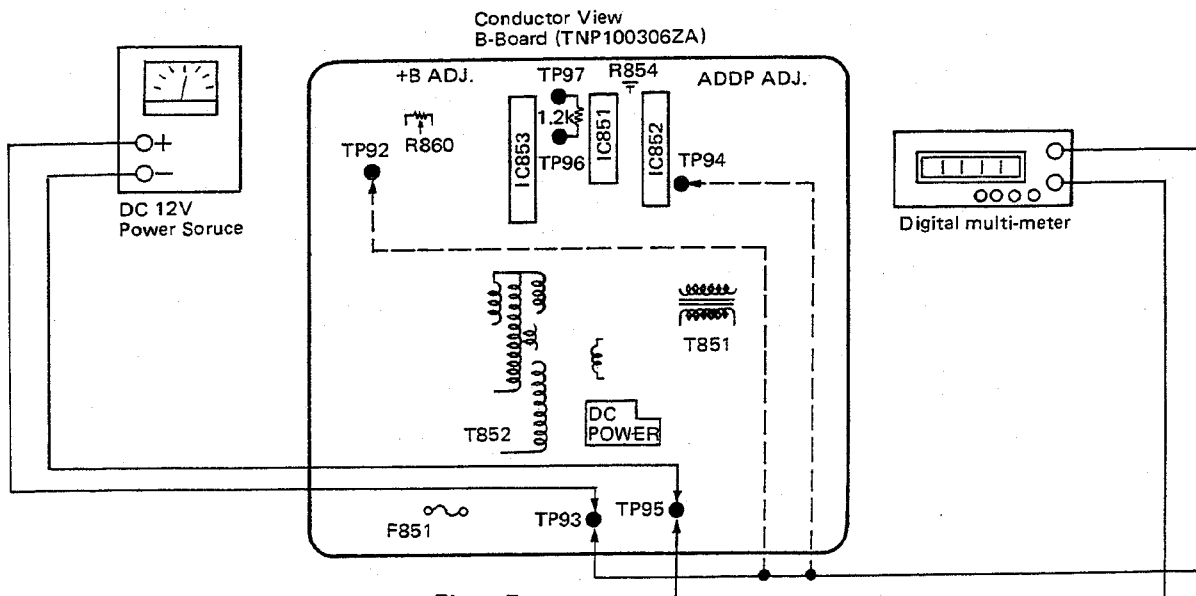

Figure 5

SUB-CONTRAST ALIGNMENT

1. Apply a studio color bar signal.
Input signal should be 1.0Vp-p (video level 0.7Vp-p, sync level 0.3Vp-p).
2. Set Brightness (R350) and Contrast (R344) controls at their click position.
3. Set Color control (R613) fully counterclockwise.
4. Connect an oscilloscope to TP48 on C-Board.
5. Adjust Sub-Contrast control (R327) to obtain 1.1Vp-p \pm 0.1Vp-p from white level to black level.
(See figure 6.)

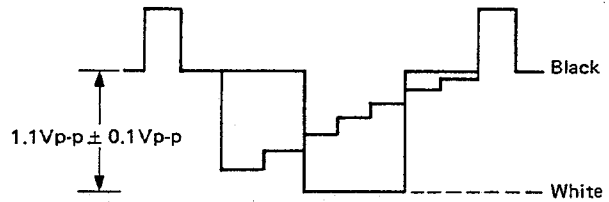

Figure 6

CIRCUIT EXPLANATION

HORIZONTAL OSC. DISABLE CIRCUIT

1. Under normal operating conditions, zener diode D512 is CUT OFF since its breakdown voltage is not reached.
2. When the amplitude of the pulse applied to diode D510 increases, the cathode voltage of zener diode D512 rises, and D512 conducts.
3. The conduction of D512 increases the base voltage of Q504 and conducts it.
4. This causes the pin ③ voltage of IC401 to decrease. As a result the horizontal oscillator frequency goes higher and the picture on the screen falls out of horizontal sync.

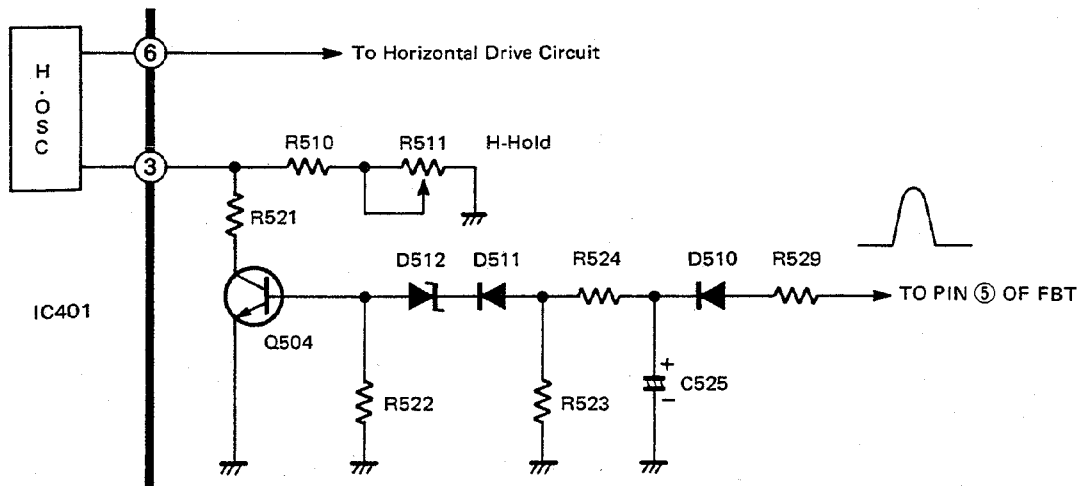
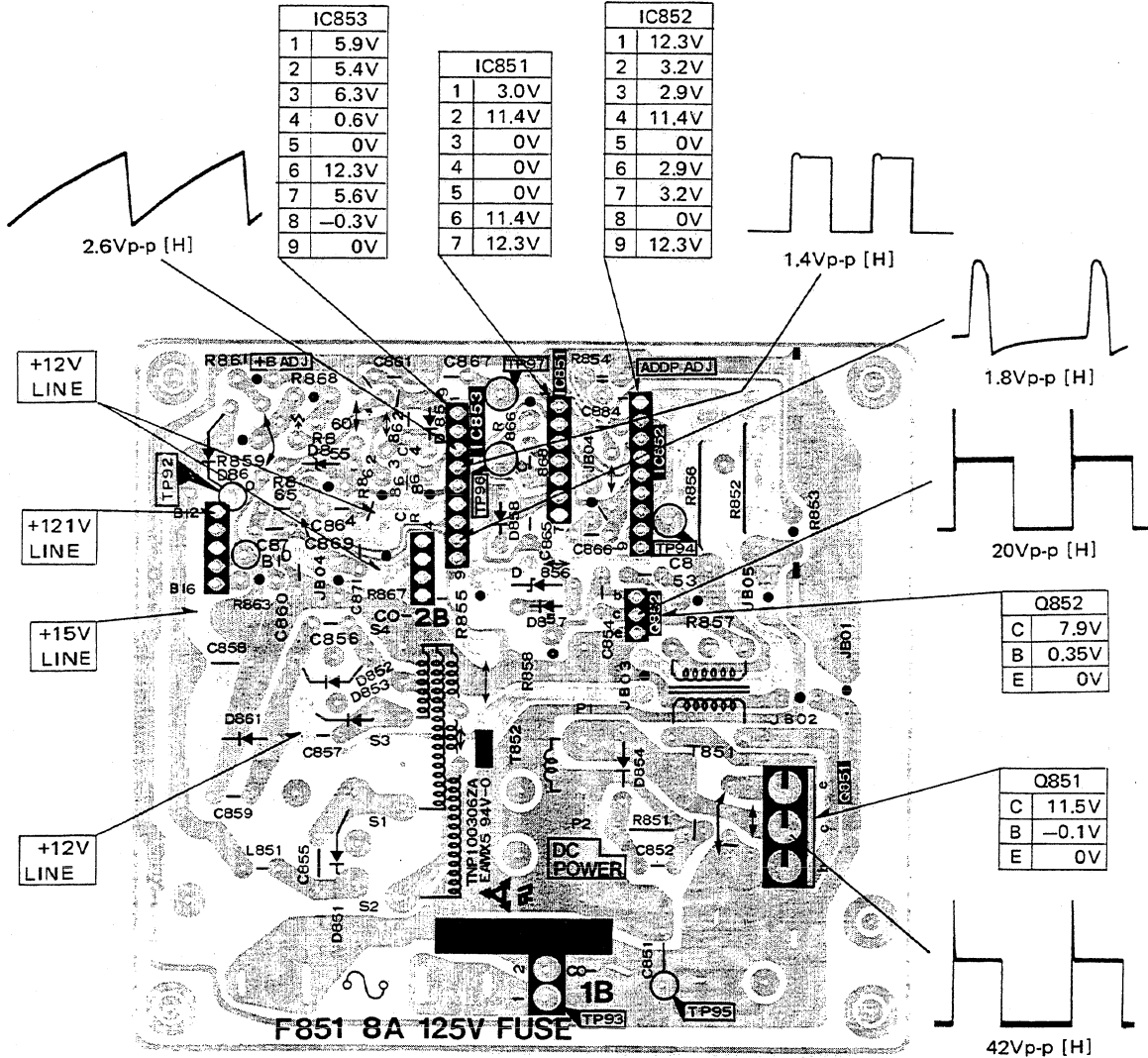

Figure 7

CONDUCTOR VIEWS

B-BOARD TNP100306ZA



C-BBOARD TNP100307CD

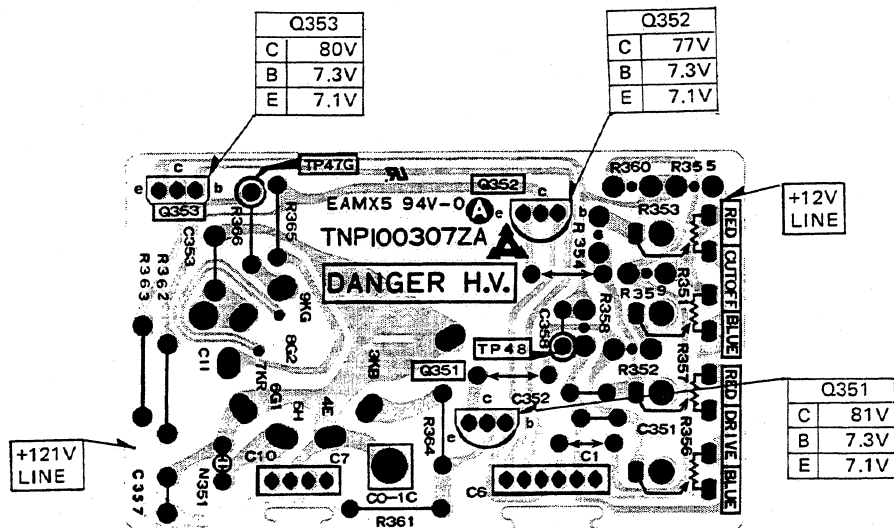

L-BBOARD TNP100311CD

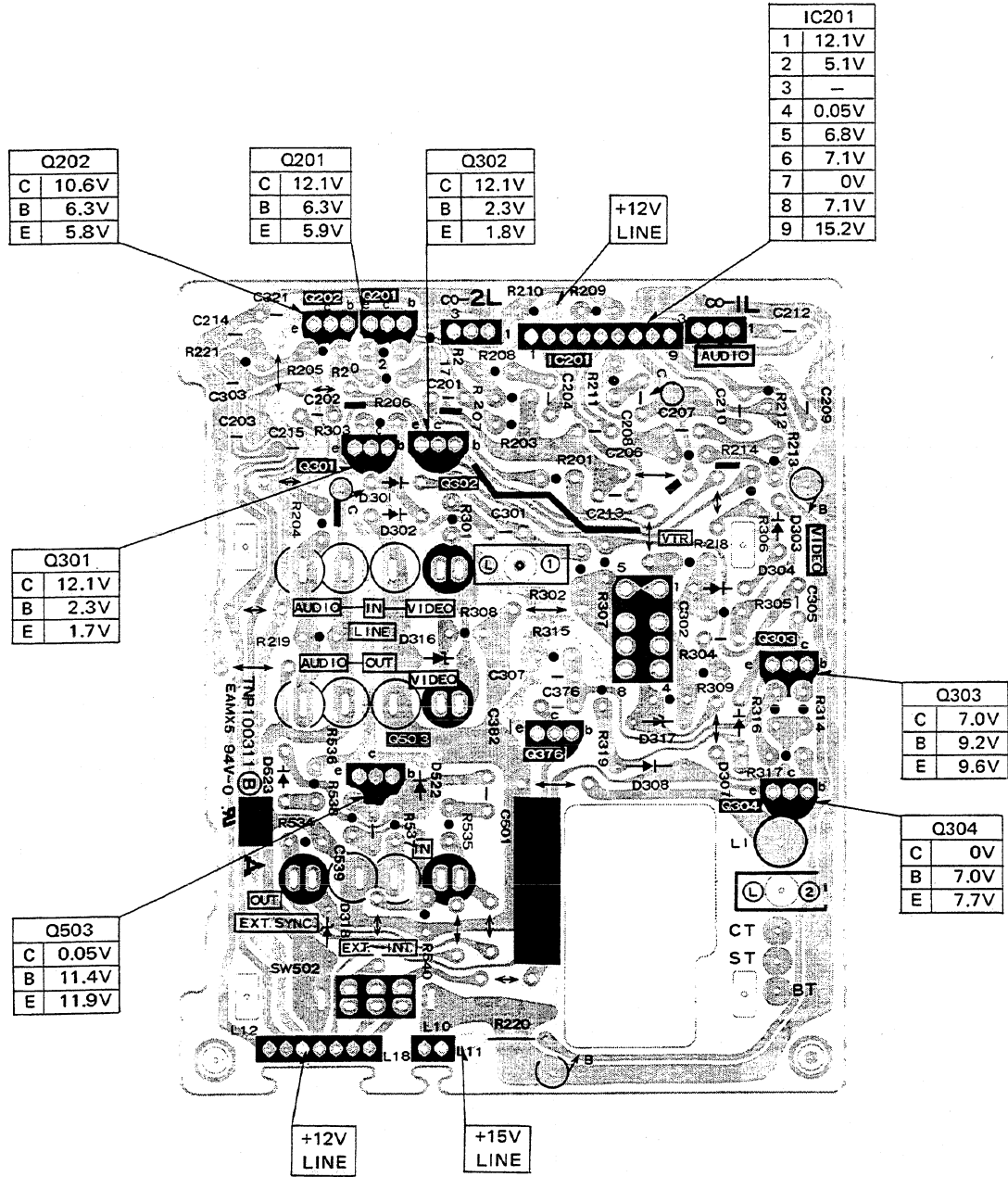

X-BBOARD TNP100312ZA

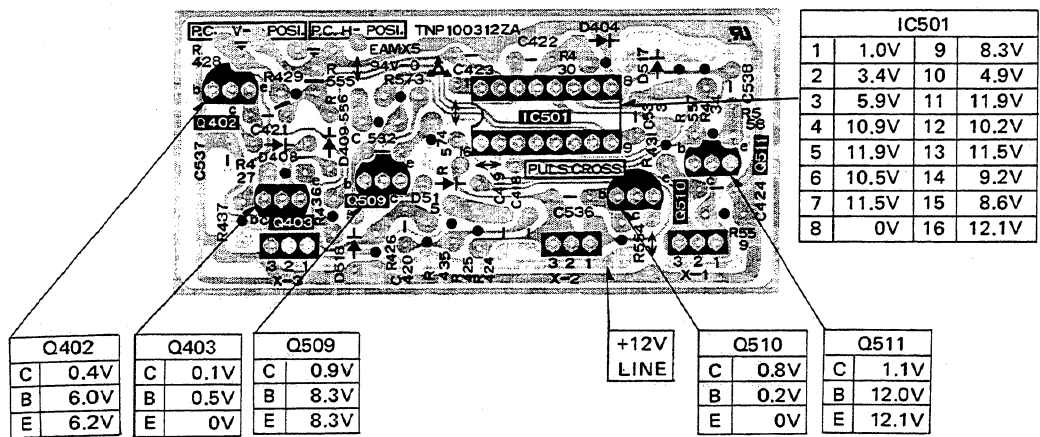

**A-BOARD
TNP190018CD**

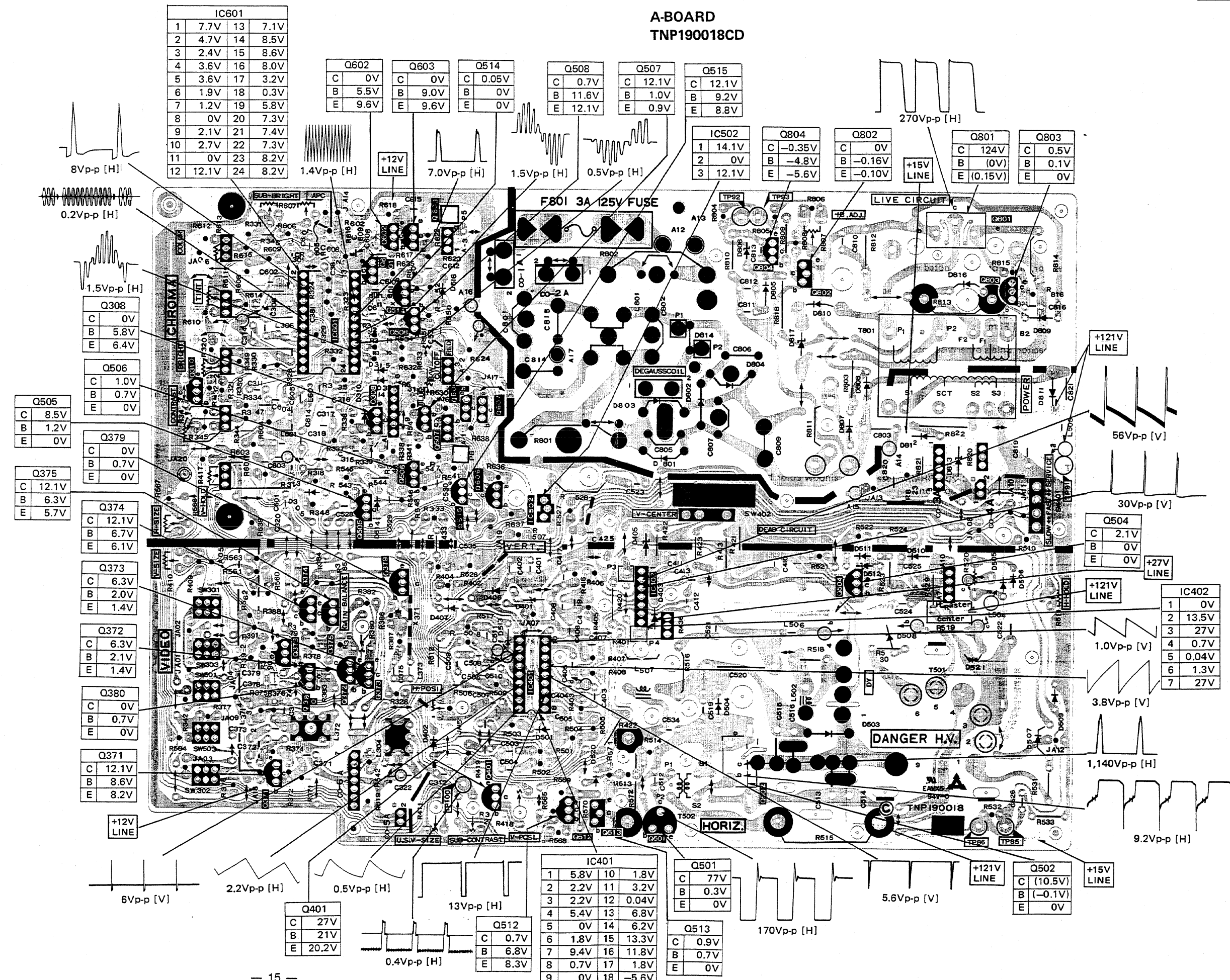

IC601			
1	7.7V	13	7.1V
2	4.7V	14	8.5V
3	2.4V	15	8.6V
4	3.6V	16	8.0V
5	3.6V	17	3.2V
6	1.9V	18	0.3V
7	1.2V	19	5.8V
8	0V	20	7.3V
9	2.1V	21	7.4V
10	2.7V	22	7.3V
11	0V	23	8.2V
12	12.1V	24	8.2V

Q602			Q603			Q514		
C	0V		C	0V		C	0.05V	
B	5.5V		B	9.0V		B	0V	
E	9.6V		E	9.6V		E	0V	

Q508			Q507			Q515		
C	0.7V		C	12.1V		C	12.1V	
B	11.6V		B	1.0V		B	9.2V	
E	12.1V		E	0.9V		E	8.8V	

IC502			Q804			Q802			Q801			Q803		
1	14.1V		C	-0.35V		C	0V		C	124V		C	0.5V	
2	0V		B	-4.8V		B	-0.16V		B	(0V)		B	0.1V	
3	12.1V		E	-5.6V		E	-0.10V		E	(0.15V)		E	0V	

Q308		
C	0V	
B	5.8V	
E	6.4V	

Q506		
C	1.0V	
B	0.7V	
E	0V	

Q505		
C	8.5V	
B	1.2V	
E	0V	

Q379		
C	0V	
B	0.7V	
E	0V	

Q375		
C	12.1V	
B	6.3V	
E	5.7V	

Q374		
C	12.1V	
B	6.7V	
E	6.1V	

Q373		
C	6.3V	
B	2.0V	
E	1.4V	

Q372		
C	6.3V	
B	2.1V	
E	1.4V	

Q380		
C	0V	
B	0.7V	
E	0V	

Q371		
C	12.1V	
B	8.6V	
E	8.2V	

Q401		
C	27V	
B	21V	
E	20.2V	

Q512		
C	0.7V	
B	6.8V	
E	8.3V	

IC401			
1	5.8V	10	1.8V
2	2.2V	11	3.2V
3	2.2V	12	0.04V
4	5.4V	13	6.8V
5	0V	14	6.2V
6	1.8V	15	13.3V
7	9.4V	16	11.8V
8	0.7V	17	1.8V
9	0V	18	-5.6V

Q501		
C	77V	
B	0.3V	
E	0V	

Q513		
C	0.9V	
B	0.7V	
E	0V	

Q502		
C	(10.5V)	
B	(-0.1V)	
E	0V	

IC402		
1	0V	
2	13.5V	
3	27V	
4	0.7V	
5	0.04V	
6	1.3V	
7	27V	

**SCHEMATIC DIAGRAM FOR MODEL BT-S1000N
CHASSIS NO. KMX-F104A**

IMPORTANT SAFETY NOTICE

THE SHADED AREA ON THIS SCHEMATIC DIAGRAM INCORPORATES SPECIAL FEATURES IMPORTANT FOR PROTECTION FROM X-RADIATION, FIRE AND ELECTRICAL SHOCK HAZARDS. WHEN SERVICING IT IS ESSENTIAL THAT ONLY MANUFACTURER'S SPECIFIED PARTS BE USED FOR THE CRITICAL COMPONENTS IN THE SHADED AREAS OF THE SCHEMATIC.

NOTE:

- All resistors are carbon 1/4W resistor, unless otherwise noted with the following marks.
Unit of resistance is OHM (Ω), (K = 1,000, M = 1,000,000).
 - Δ : Solid
 - \square : Wire Wound
 - \circ : Non-flammable
 - \square with diagonal line : Cement
 - ∇ : Thermistor
 - \otimes : Fuse
 - \boxtimes : Metal Oxide
 - \odot : Metal Film
 - \ominus : Leadless Type
- CAPACITOR**
All capacitors are ceramic 50V capacitor, unless otherwise noted with the following marks.
Unit of capacitance is μ F, unless otherwise noted.
 - --- : Electrolytic
 - --- with 'N' : NP : Bipolar
 - --- with 'Z' : Z Type
 - --- with 'T' : Tantalum
 - --- with 'NH' : NH Type
 - --- with 'TiO' : Titanium Oxide
 - --- with 'TC' : Temp Compensation
 - --- with 'M' : Polyester
 - --- with 'S' : Polystyrene
 - --- with 'PP' : Polypropylene
 - --- with 'MP' : Metalized Polyester
- COIL**
Unit of inductance is μ H.
- TEST POINT**
 ∇ : Test point position.
- VOLTAGE MEASUREMENT**
Voltage is measured by a volt ohm meter with DC 20k OHM/V receiving a rainbow color bar signal when all customer's controls are set to the maximum position.
- When arrow mark (\rightarrow) is found, connection is easily found along with the direction of an arrow.
- This schematic diagram is the latest at the time of printing and subject to change without notice.

	EMITTER COLLECTOR BASE	2SD1457A 2SD1457AKU 2SC3872		BASE COLLECTOR EMITTER	2SC1098(4) 2SB547 2SC1446 2SC1448 2SC1507 2SD402 2SA636(4) 2SC1505(11)
		TVSS1854		FACE	
	BASE COLLECTOR EMITTER	2SD1199 2SD1198 2SD638 2SD637 2SD636 2SB641 2SB642 2SB643 2SD973 2SC2188 2SC2377		BASE COLLECTOR EMITTER	2SA900 2SC2911 2SD946 2SA885
		AN78M05		CATHODE GATE ANODE	N13T1
				CATHODE ANODE GATE	03P2M
	BASE COLLECTOR EMITTER	2SC1383NC 2SC1473AH 2SC1473NC 2SC945A 2SC1317 2SD893 2SA564 2SA564A 2SC1573ANC 2SC1685 2SC1688 2SC1685CH 2SC1684 2SD965 2SB774 2SD889		EMITTER COLLECTOR BASE	2SD1266
	BASE COLLECTOR EMITTER			EMITTER COLLECTOR BASE	2SC3300A 2SC3088 2SD1044A 2SD1439

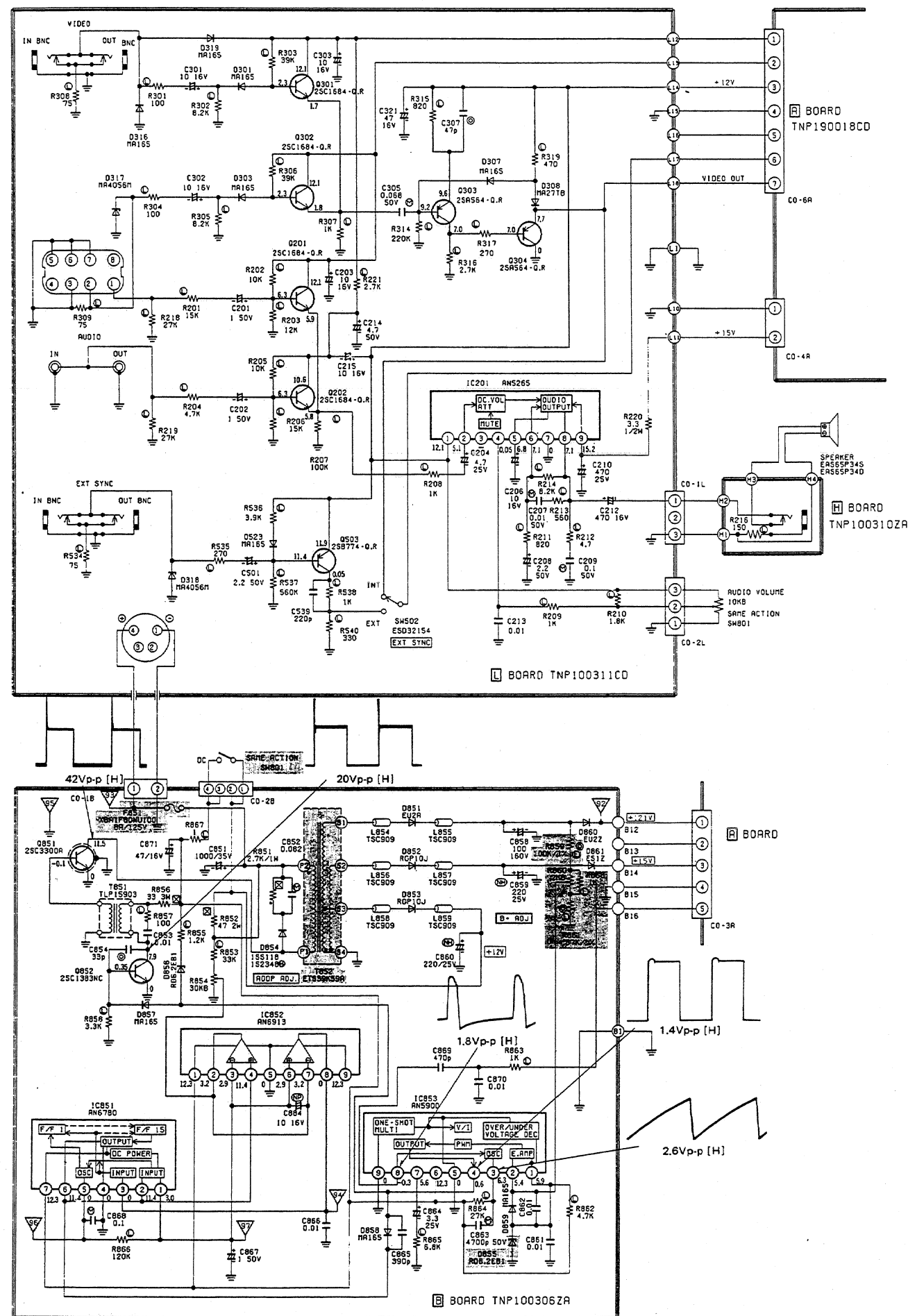

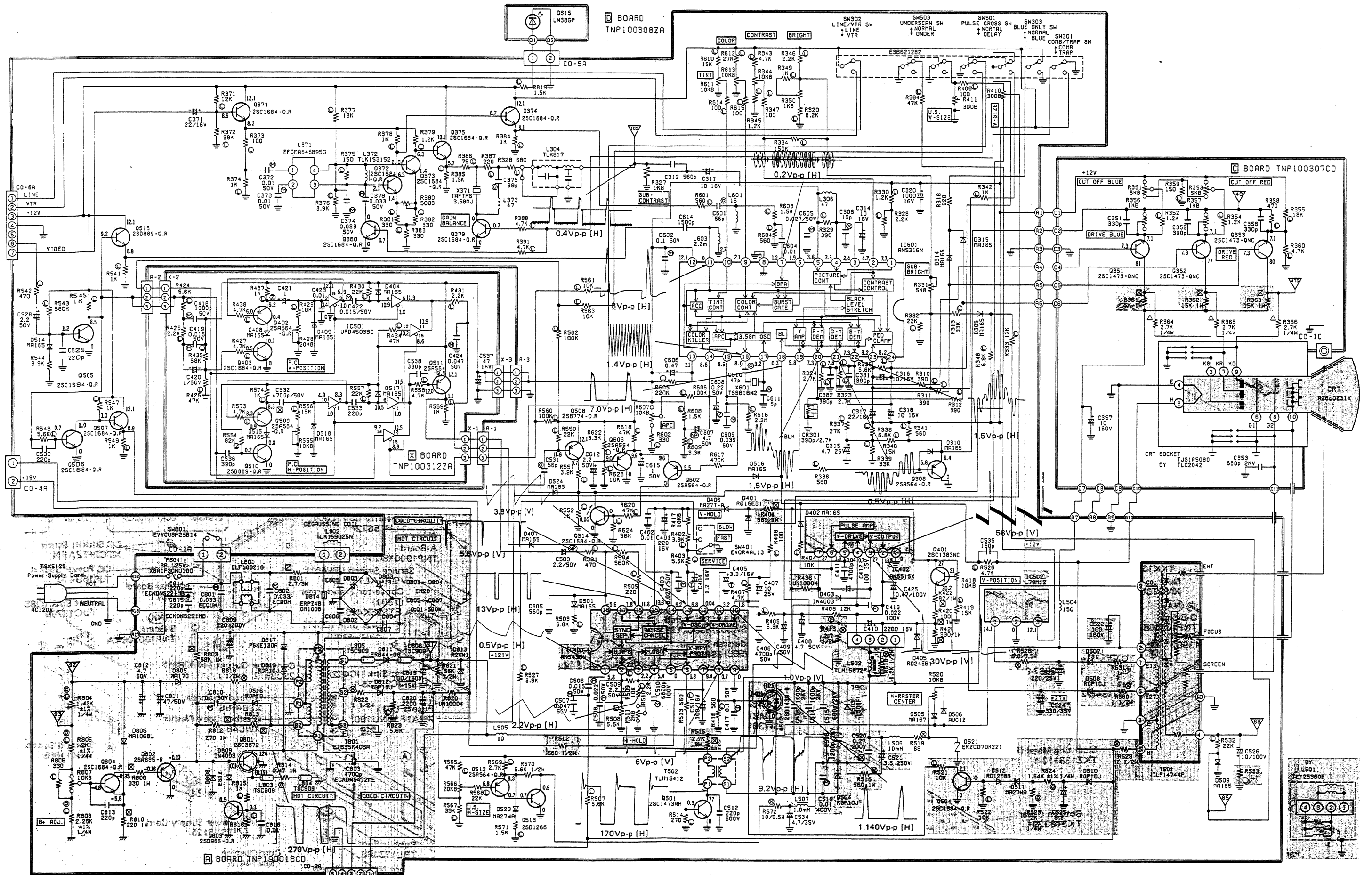

BT-S1000N BT-S1000N

EXPLODED VIEWS

NOTE: Parts or Components marked with (NA) and unlisted are not available as a replacement parts.

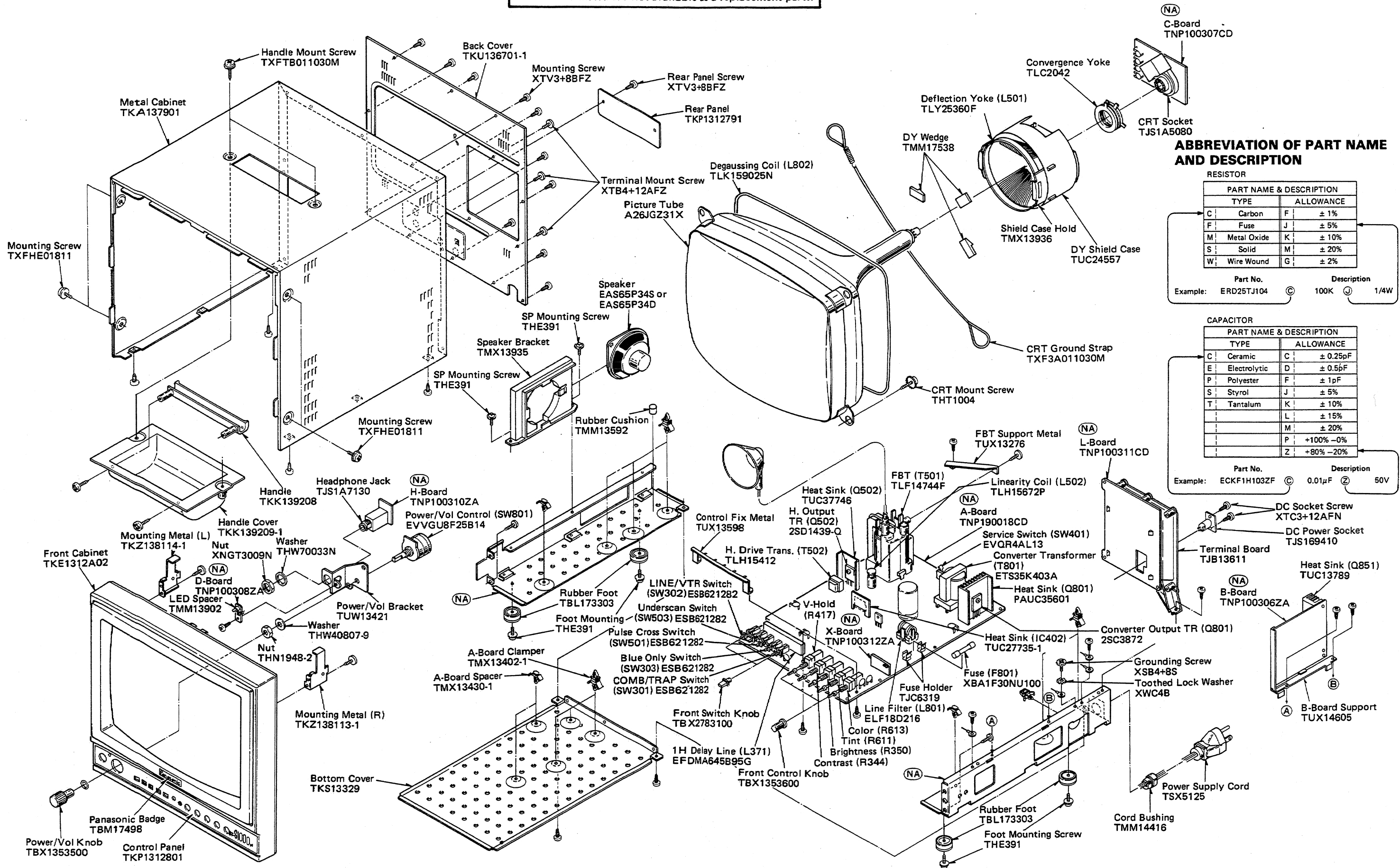

ABBREVIATION OF PART NAME AND DESCRIPTION

RESISTOR

PART NAME & DESCRIPTION	
TYPE	ALLOWANCE
C Carbon	F ± 1%
F Fuse	J ± 5%
M Metal Oxide	K ± 10%
S Solid	M ± 20%
W Wire Wound	G ± 2%

Part No. Description
 Example: ERD25TJ104 100K 1/4W

CAPACITOR

PART NAME & DESCRIPTION	
TYPE	ALLOWANCE
C Ceramic	C ± 0.25pF
E Electrolytic	D ± 0.5pF
P Polyester	F ± 1pF
S Styrol	J ± 5%
T Tantalum	K ± 10%
	L ± 15%
	M ± 20%
	P +100% -0%
	Z +80% -20%

Part No. Description
 Example: ECKF1H103ZF 0.01μF 50V

REPLACEMENT PARTS LIST

Important Safety Notice

Components identified by shaded area have special characteristics important for safety. When replacing any of these components use only manufacturer's specified parts.

Note: TNP190018CD (A-Board), TNP100306ZA (B-Board), TNP100307CD (C-Board), TNP100308ZA (D-Board), TNP100310ZA (H-Board), TNP100311CD (L-Board), and TNP100312ZA (X-Board) are not available as a complete printed circuit board.

Ref. No.	Part No.	Description	Ref. No.	Part No.	Description
RESISTORS			R327	EVN61AA00B13	CONTROL B 1Kohm
R201	ERD25TLJ153	C 15Kohm J 1/4W	R328	ERD25TLJ681	C 680ohm J 1/4W
R202	ERD25TLJ103	C 10Kohm J 1/4W	R329	ERD25TLJ391	C 390ohm J 1/4W
R203	ERD25TLJ123	C 12Kohm J 1/4W	R330	ERD25TLJ122	C 1.2Kohm J 1/4W
R204	ERD25TLJ472	C 4.7Kohm J 1/4W	R331	EVN60AA00B53	CONTROL B 5Kohm
R205	ERD25TLJ103	C 10Kohm J 1/4W	R332	ERD25TLJ223	C 22Kohm J 1/4W
R206	ERD25TLJ153	C 15Kohm J 1/4W	R333	ERD25TLJ123	C 12Kohm J 1/4W
R207	ERD25TLJ104	C 100Kohm J 1/4W	R334	ERD25TLJ154	C 150Kohm J 1/4W
R208	ERD25TLJ102	C 1Kohm J 1/4W	R335	ERD25TLJ562	C 5.6Kohm J 1/4W
R209	ERD25TLJ102	C 1Kohm J 1/4W	R336	ERD25TLJ561	C 560ohm J 1/4W
R210	ERD25TLJ182	C 1.8Kohm J 1/4W	R337	ERD25TLJ273	C 27Kohm J 1/4W
R211	ERD25TLJ821	C 820ohm J 1/4W	R338	ERD25TLJ682	C 6.8Kohm J 1/4W
R212	ERD25TLJ4R7	C 4.7ohm J 1/4W	R339	ERD25TLJ333	C 33Kohm J 1/4W
R213	ERD25TLJ561	C 560ohm J 1/4W	R340	ERD25TLJ153	C 15Kohm J 1/4W
R214	ERD25TLJ822	C 8.2Kohm J 1/4W	R341	ERD25TLJ561	C 560ohm J 1/4W
R216	ERD25TLJ151	C 150ohm J 1/4W	R342	ERD25TLJ102	C 1Kohm J 1/4W
R217	ERD25TL0	0 ohm Resistor	R343	ERD25TLJ472	C 4.7Kohm J 1/4W
R218	ERD25TLJ273	C 27Kohm J 1/4W	R344	EVU9LA006B14	CONTROL B 10Kohm
R219	ERD25TLJ273	C 27Kohm J 1/4W	R345	ERD25TLJ122	C 1.2Kohm J 1/4W
R220	ERDS1TJ3R3	C 3.3ohm J 1/2W	R346	ERD25TLJ222	C 2.2Kohm J 1/4W
R221	ERD25TLJ272	C 2.7Kohm J 1/4W	R347	ERD25TLJ101	C 100ohm J 1/4W
R301	ERD25TLJ101	C 100ohm J 1/4W	R348	ERD25TLJ682	C 6.8Kohm J 1/4W
R302	ERD25TLJ822	C 8.2Kohm J 1/4W	R349	ERD25TLJ102	C 1Kohm J 1/4W
R303	ERD25TLJ393	C 39Kohm J 1/4W	R350	EVU2LA006B13	CONTROL B 1Kohm
R304	ERD25TLJ101	C 100ohm J 1/4W	R351	EVN61AA00B53	CONTROL B 5Kohm
R305	ERD25TLJ822	C 8.2Kohm J 1/4W	R352	ERD25TLJ122	C 1.2Kohm J 1/4W
R306	ERD25TLJ393	C 39Kohm J 1/4W	R353	EVN61AA00B53	CONTROL B 5Kohm
R307	ERD25TLJ102	C 1Kohm J 1/4W	R354	ERD25TLJ122	C 1.2Kohm J 1/4W
R308	ERD25TLJ750	C 75ohm J 1/4W	R355	ERD25TLJ183	C 18Kohm J 1/4W
R309	ERD25TLJ750	C 75ohm J 1/4W	R356	EVN61AA00B13	CONTROL B 1Kohm
R310	ERD25TLJ391	C 390ohm J 1/4W	R357	EVN61AA00B13	CONTROL B 1Kohm
R311	ERD25TLJ391	C 390ohm J 1/4W	R358	ERD25TLJ471	C 470ohm J 1/4W
R312	ERD25TLJ391	C 390ohm J 1/4W	R359	ERD25TLJ151	C 150ohm J 1/4W
R313	ERD25TLJ333	C 33Kohm J 1/4W	R360	ERD25TLJ472	C 4.7Kohm J 1/4W
R314	ERD25TLJ224	C 220Kohm J 1/4W	R361	ERG15J153P	M 15Kohm J 1W
R315	ERD25TLJ821	C 820ohm J 1/4W	R362	ERG15J153P	M 15Kohm J 1W
R316	ERD25TLJ272	C 2.7Kohm J 1/4W	R363	ERG15J153P	M 15Kohm J 1W
R317	ERD25TLJ271	C 270ohm J 1/4W	R364	ERC14GK272	S 2.7Kohm K 1/4W
R318	ERDS2TJ221	C 220ohm J 1/4W	R365	ERC14GK272	S 2.7Kohm K 1/4W
R319	ERD25TLJ471	C 470ohm J 1/4W	R366	ERC14GK272	S 2.7Kohm K 1/4W
R320	ERD25TLJ822	C 8.2Kohm J 1/4W	R371	ERD25TLJ123	C 12Kohm J 1/4W
R323	ERD25TLJ272	C 2.7Kohm J 1/4W	R372	ERD25TLJ393	C 39Kohm J 1/4W
R324	ERD25TLJ272	C 2.7Kohm J 1/4W	R373	ERD25TLJ101	C 100ohm J 1/4W
R326	ERD25TLJ222	C 2.2Kohm J 1/4W	R374	ERD25TLJ102	C 1Kohm J 1/4W
			R375	ERD25TLJ151	C 150ohm J 1/4W

BT-S1000N

Ref. No.	Part No.	Description	Ref. No.	Part No.	Description
R376	ERD25TLJ392	C 3.9Kohm J 1/4W	R438	ERD25TLJ472	C 4.7Kohm J 1/4W
R377	ERD25TLJ183	C 18Kohm J 1/4W	R501	ERD25TLJ471	C 470ohm J 1/4W
R378	ERD25TLJ102	C 1Kohm J 1/4W	R503	ERD25TLJ682	C 6.8Kohm J 1/4W
R379	ERD25TLJ122	C 1.2Kohm J 1/4W	R504	ERD25TLJ564	C 560Kohm J 1/4W
R380	EVN61AA00B52	CONTROL B 500ohm	R505	ERD25TLJ221	C 220ohm J 1/4W
R381	ERD25TLJ331	C 330ohm J 1/4W	R507	ERD25TLJ562	C 5.6Kohm J 1/4W
R382	ERD25TLJ331	C 330ohm J 1/4W	R508	ERD25TLJ562	C 5.6Kohm J 1/4W
R383	ERD25TLJ331	C 330ohm J 1/4W	R509	ERD25TLJ103	C 10Kohm J 1/4W
R384	ERD25TLJ102	C 1Kohm J 1/4W	R510	ERD25TLJ222	C 2.2Kohm J 1/4W
R385	ERD25TLJ152	C 1.5Kohm J 1/4W	R511	EVN60AA00B23	CONTROL B 2Kohm
R386	ERD25TLJ750	C 75ohm J 1/4W	R512	ERD51TJ561	C 560ohm J 1/2W
R387	ERD25TLJ221	C 220ohm J 1/4W	R513	ERD25TLJ561	C 560ohm J 1/4W
R388	ERD25TLJ472	C 4.7Kohm J 1/4W	R514	ERD25TLJ271	C 270ohm J 1/4W
R391	ERD25TLJ472	C 4.7Kohm J 1/4W	R515	ERG3ANJ272H	M 2.7Kohm J 3W
R401	ERG1SJ561P	M 560ohm J 1W	R516	ERD1AJP561S	F 560ohm J 1W
R402	ERD25TLJ392	C 3.9Kohm J 1/4W	R517	ERD25TL0	0 ohm Resistor
R403	ERD25TLJ562	C 5.6Kohm J 1/4W	R518	ERD12HJ122	F 1.2Kohm J 1/2W
R404	ERD25TLJ103	C 10Kohm J 1/4W	R519	ERD2FCG680P	F 68ohm G 1/4W
R405	ERD25TLJ562	C 5.6Kohm J 1/4W	R520	EVMJ6U10KB14	CONTROL B 10Kohm
R406	ERD25TLJ123	C 12Kohm J 1/4W	R521	ERD25TLJ103	C 10Kohm J 1/4W
R407	ERD25TLJ472	C 4.7Kohm J 1/4W	R522	ERD25TLJ103	C 10Kohm J 1/4W
R408	ERD25TLJ101	C 100ohm J 1/4W	R523	ERG25CKF2001	M 2Kohm F 1/4W
R409	ERD25TLJ101	C 100ohm J 1/4W	R524	ERG25CKF1541	M 1.54Kohm F 1/4W
R410	EVN60AA00B32	CONTROL B 300ohm	R526	ERD25TLJ472	C 4.7Kohm J 1/4W
R411	EVN61AA00B32	CONTROL B 300ohm	R527	ERD25TLJ392	C 3.9Kohm J 1/4W
R413	ERD12AJ2R7F	F 2.7ohm J 1/2W	R528	ERD12HK6R8P	F 6.8ohm K 1/2W
R416	ERD25TLJ561	C 560ohm J 1/4W	R529	ERD12AZJ1R0P	F 1ohm J 1/2W
R417	EVU8LA006B14	CONTROL B 10Kohm	R530	ERD12HJ1R0	F 1ohm J 1/2W
R418	EVN61AA00B14	CONTROL B 10Kohm	R531	ERD25FJ1R0P	C 1ohm J 1/4W
R419	ERD25TLJ153	C 15Kohm J 1/4W	R532	ERD25TLJ223	C 22Kohm J 1/4W
R420	ERG1SJ101P	M 100ohm J 1W	R533	ERD25FJ1R0P	C 1ohm J 1/4W
R421	ERG1ANJP331S	M 330ohm J 1W	R534	ERD25TLJ750	C 75ohm J 1/4W
R422	ERG1SJ820P	M 82ohm J 1W	R535	ERD25TLJ271	C 270ohm J 1/4W
R424	ERD25TLJ562	C 5.6Kohm J 1/4W	R536	ERD25TLJ392	C 3.9Kohm J 1/4W
R425	ERD25TLJ222	C 2.2Kohm J 1/4W	R537	ERD25TLJ564	C 560Kohm J 1/4W
R426	ERD25TLJ473	C 47Kohm J 1/4W	R538	ERD25TLJ102	C 1Kohm J 1/4W
R427	ERD25TLJ472	C 4.7Kohm J 1/4W	R540	ERD25TLJ331	C 330ohm J 1/4W
R428	EVN60AA00B24	CONTROL B 20Kohm	R541	ERD25TLJ102	C 1Kohm J 1/4W
R429	ERD25TLJ103	C 10Kohm J 1/4W	R542	ERD25TLJ471	C 470ohm J 1/4W
R430	ERD25TLJ223	C 22Kohm J 1/4W	R543	ERD25TLJ564	C 560Kohm J 1/4W
R431	ERD25TLJ222	C 2.2Kohm J 1/4W	R544	ERD52TJ392	C 3.9Kohm J 1/4W
R434	ERD25TLJ473	C 47Kohm J 1/4W	R545	ERD25TLJ102	C 1Kohm J 1/4W
R435	ERD25TLJ683	C 68Kohm J 1/4W	R547	ERD25TLJ102	C 1Kohm J 1/4W
R436	UN10004	Current Protector	R548	ERD25TLJ562	C 5.6Kohm J 1/4W
R437	ERD25TLJ102	C 1Kohm J 1/4W	R549	ERD25TLJ102	C 1Kohm J 1/4W

Ref. No.	Part No.	Description	Ref. No.	Part No.	Description
R550	ERD25TLJ223	C 22Kohm J 1/4W	R624	ERD25TLJ563	C 56Kohm J 1/4W
R551	ERD25TLJ392	C 3.9Kohm J 1/4W	R801	ERF3AK2R7	W 2.7ohm K 3W
R552	ERD25TLJ102	C 1Kohm J 1/4W	R803	ERG1ANJ683H	M 68Kohm J 1W
R554	ERD25TLJ823	C 82Kohm J 1/4W	R804	ERD25LKF1431	M 1.43Kohm F 1/4W
R555	EVN60AA00B14	CONTROL B 10Kohm	R805	ERD25LKF2001	M 2Kohm F 1/4W
R556	ERD25TLJ153	C 15Kohm J 1/4W	R806	ERD25TLJ331	C 330ohm J 1/4W
R557	ERD25TLJ223	C 22Kohm J 1/4W	R807	EVN61AA00B14	CONTROL B 10Kohm
R558	ERD25TLJ472	C 4.7Kohm J 1/4W	R808	ERD25LKF2261	M 2.26Kohm F 1/4W
R559	ERD25TLJ102	C 1Kohm J 1/4W	R809	ERG15J331F	M 330ohm J 1W
R560	ERD25TLJ104	C 100Kohm J 1/4W	R810	ERG15J221F	M 220ohm J 1W
R561	ERD25TLJ103	C 10Kohm J 1/4W	R812	ERG15J271F	M 270ohm J 1W
R562	ERD25TLJ104	C 100Kohm J 1/4W	R813	ERG2ANJ330H	M 33ohm J 2W
R563	ERD25TLJ103	C 10Kohm J 1/4W	R814	ERX1ANJR47	M 0.47ohm J 1W
R564	ERD25TLJ473	C 47Kohm J 1/4W	R815	ERD25TLJ102	C 1Kohm J 1/4W
R565	ERD25TLJ473	C 47Kohm J 1/4W	R816	ERD25TLJ102	C 1Kohm J 1/4W
R566	EVN60AA00B24	CONTROL B 20Kohm	R818	ERQ12HK1R0P	F 1ohm K 1/2W
R567	ERD25TLJ333	C 33Kohm J 1/4W	R819	ERD25TLJ152	C 1.5Kohm J 1/4W
R568	ERD25TLJ223	C 22Kohm J 1/4W	R820	UN10004	Current Protector
R569	ERD25TLJ272	C 2.7Kohm J 1/4W	R821	ERDS1TJ563	C 56Kohm J 1/2W
R570	ERDS1TJ562	C 5.6Kohm J 1/2W	R822	ERQ12HJ1R0P	F 1ohm J 1/2W
R571	ERD25TLJ152	C 1.5Kohm J 1/4W	R823	ERD25TLJ562	C 5.6Kohm J 1/4W
R572	ERQ12HJ100P	F 10ohm J 1/2W	R851	ERG15J272F	M 2.7Kohm J 1W
R573	ERD25TLJ472	C 4.7Kohm J 1/4W	R852	ERG2ANJ470	M 47ohm J 2W
R574	ERD25TLJ102	C 1Kohm J 1/4W	R853	ERD25TLJ333	C 33Kohm J 1/4W
R601	ERD25TLJ561	C 560ohm J 1/4W	R854	EVN60AA00B34	CONTROL B 30Kohm
R602	ERD25TLJ331	C 330ohm J 1/4W	R855	ERD25TLJ122	C 1.2Kohm J 1/4W
R603	ERD25TLJ152	C 1.5Kohm J 1/4W	R856	ERG36J330	M 33ohm J 3W
R604	ERD25TLJ561	C 560ohm J 1/4W	R857	ERD25TLJ101	C 100ohm J 1/4W
R605	ERD25TLJ224	C 220Kohm J 1/4W	R858	ERD25TLJ332	C 3.3Kohm J 1/4W
R606	ERD25TLJ104	C 100Kohm J 1/4W	R859	ERD25LKF1003	M 100Kohm F 1/4W
R607	EVN60AA00B14	CONTROL B 10Kohm	R860	EVN60AA00B23	CONTROL B 2Kohm
R608	ERD25TLJ152	C 1.5Kohm J 1/4W	R861	ERD25LKF4871	M 4.87Kohm F 1/4W
R609	ERD25TLJ332	C 3.3Kohm J 1/4W	R862	ERD25TLJ472	C 4.7Kohm J 1/4W
R610	ERD25TLJ153	C 15Kohm J 1/4W	R863	ERD25TLJ102	C 1Kohm J 1/4W
R611	EVU8LA006B14	CONTROL B 10Kohm	R864	ERD25TLJ273	C 27Kohm J 1/4W
R612	ERD25TLJ273	C 27Kohm J 1/4W	R865	ERD25TLJ682	C 6.8Kohm J 1/4W
R613	EVU8LA006B14	CONTROL B 10Kohm	R866	ERD25TLJ124	C 120Kohm J 1/4W
R614	ERD25TLJ101	C 100ohm J 1/4W	R867	ERD25TLJ1R0	C 1ohm J 1/4W
R615	ERD25TLJ101	C 100ohm J 1/4W	R868	ERD25TLJ102	C 1Kohm J 1/4W
R616	ERD25TLJ225	C 2.2Mohm J 1/4W	CAPACITORS		
R617	ERDS2TJ474	C 470Kohm J 1/4W	C201	ECEA1HU010	E 1uF 50V
R618	ERD25TLJ473	C 47Kohm J 1/4W	C202	ECEA1HU010	E 1uF 50V
R620	ERD25TLJ473	C 47Kohm J 1/4W	C203	ECEA1CU100	E 10uF 16V
R622	ERD25TLJ332	C 3.3Kohm J 1/4W	C204	ECEA1EU4R7	E 4.7uF 25V
R623	ERD25TLJ103	C 10Kohm J 1/4W			

BT-S1000N

Ref. No.	Part No.	Description	Ref. No.	Part No.	Description
C206	ECEA1CU100	E 10uF 16V	C409	ECEA1HU010	E 1uF 50V
C207	ECQM1H103KV	P 0.01uF K 50V	C410	ECEA1CU222	E 2200uF 16V
C208	ECEA1HU2R2	E 2.2uF 50V	C411	ECKF1H472KB	C 4700pF K 50V
C209	ECQM1H104KV	P 0.1uF K 50V	C412	ECEA1VU101	E 100uF 35V
C210	ECEA1EU471	E 470uF 25V	C413	ECQM1223KZ	P 0.022uF K 100V
C212	ECEA1CU471	E 470uF 16V	C417	ECQM1H104KV	P 0.1uF K 50V
C213	ECKF1H103ZF	C 0.01uF Z 50V	C418	ECQM1H102KV	P 1000pF K 50V
C214	ECEA1HU4R7	E 4.7uF 50V	C419	ECQM1H153KV	P 0.015uF K 50V
C215	ECEA1CU100	E 10uF 16V	C420	ECEA1HK010	E 1uF 50V
C301	ECEA1CK100	E 10uF 16V	C421	ECEA50Z1	E 1uF 50V
C302	ECEA1CK100	E 10uF 16V	C422	ECQM1H153KV	P 0.015uF K 50V
C303	ECEA1CU100	E 10uF 16V	C423	ECKF1H103ZF	C 0.01uF Z 50V
C305	ECQM1H683KV	P 0.068uF K 50V	C424	ECQM1H473KV	P 0.047uF K 50V
C307	ECCF1H470J	C 47pF J 50V	C425	ECEA2AGR47S	E 0.47uF 100V
C308	ECCF1H100DC	C 10pF D 50V	C501	ECEA1HK2R2	E 2.2uF K 50V
C311	ECEA1CU100	E 10uF 16V	C503	ECEA1HN2R2S	E 2.2uF 50V
C312	ECKF1H561KB	C 560pF K 50V	C505	ECKF1H561KB	C 560pF K 50V
C314	ECEA1CU100	E 10uF 16V	C506	ECQM1H153KV	P 0.015uF K 50V
C315	ECEA1EU4R7	E 4.7uF 25V	C507	ECQM1H473KV	P 0.047uF K 50V
C316	ECEA1CU100	E 10uF 16V	C508	ECQM1H223KV	P 0.022uF K 50V
C317	ECEA1CU220	E 22uF 16V	C509	ECEA1HU2R2	E 2.2uF 50V
C318	ECEA1CU100	E 10uF 16V	C510	ECQK1682JZ	P 6800pF J 100V
C320	ECEA1CU102	E 1000uF 16V	C511	ECEA1CU101	E 100uF 16V
C321	ECEA1CU470	E 47uF 16V	C512	ECKD2H221KB2	C 220pF K 500V
C351	ECKF1H331KB	C 330pF K 50V	C513	ECKD3D102JBN	C 1000pF J 2KV
C352	ECKF1H391KB	C 390pF K 50V	C514	ECKD3D102JBN	C 1000pF J 2KV
C353	ECKD3D681KBN	C 680pF K 2KV	C515	ECKD3D681JBN	C 680pF J 2KV
C357	ECEA2CS100	E 10uF 160V	C516	ECKD3D122JBN	C 1200pF J 2KV
C358	ECKF1H331KB	C 330pF K 50V	C519	ECQM4103JZ	P 0.01uF J 400V
C371	ECEA1CU220	E 22uF 16V	C520	ECQF2H274JZA	P 0.27uF J 200V
C372	ECQM1H103KV	P 0.01uF K 50V	C521	ECEA2ES3R3	E 3.3uF 250V
C373	ECQM1H103KV	P 0.01uF K 50V	C522	ECEA2CS101	E 100uF 160V
C374	ECQM1H333KV	P 0.033uF K 50V	C523	ECEA1EU221	E 220uF 25V
C375	ECCF1H390J	C 39pF J 50V	C524	ECEA1VU331	E 330uF 35V
C378	ECQM1H333KV	P 0.033uF K 50V	C525	ECEA1EU3R3	E 3.3uF 25V
C381	TCBL1H391KB	C 390pF K 50V	C526	ECEA2AU100	E 10uF 100V
C382	TCBL1H391KB	C 390pF K 50V	C528	ECEA1HU2R2	E 2.2uF 50V
C401	ECEA1CU221	E 220uF 16V	C529	ECKF1H221KB	C 220pF K 50V
C402	ECKF1H103ZF	C 0.01uF Z 50V	C530	ECKF1H221KB	C 220pF K 50V
C403	ECQM1H273KV	P 0.027uF K 50V	C531	ECCF1H560J	C 56pF J 50V
C404	ECSZ16EF2R2V	T 2.2uF 16V	C532	ECQP1H472JZ	P 4700pF J 50V
C405	ECSZ16EF3R3N	T 3.3uF 16V	C533	ECKF1H221KB	C 220pF K 50V
C406	ECKF1H472KB	C 4700pF K 50V	C534	ECEA35W4R70	E 4.7uF 35V
C407	ECEA1EU100	E 10uF 25V	C535	ECKF1H151KB	C 150pF K 50V
C408	ECEA1HU4R7	E 4.7uF 50V	C536	ECKF1H391KB	C 390pF K 50V

Ref. No.	Part No.	Description	Ref. No.	Part No.	Description
C537	ECEA1CU470	E 47uF 16V	C867	ECEA1HU010	E 1uF 50V
C538	ECKF1H331KB	C 330pF K 50V	C868	ECQM1H104KV	F 0.1uF K 50V
C539	ECKF1H221KB	C 220pF K 50V	C869	ECKF1H471KB	C 470pF K 50V
C601	ECCF1H560J	C 56pF J 50V	C870	ECKF1H103ZF	C 0.01uF Z 50V
C602	ECQM1H104KV	F 0.1uF K 50V	C871	ECEA1CU470	E 47uF 16V
C604	ECKF1H103ZF	C 0.01uF Z 50V	C884	ECEA1CN100S	E 10uF 16V
C605	ECQM1H273KV	F 0.027uF K 50V	CR301	EXRP391K272S	C-R Combination
C606	ECEA1HUR47	E 0.47uF 50V	COILS		
C607	ECEA1HN4R7S	E 4.7uF 50V	L304	TLKB17	Delay Line
C608	ECEA50ZR22	E 0.22uF 50V	L306	TLT470K266	Peaking 47uH
C609	ECQM1H393KV	F 0.039uF K 50V	L371	EFDMA645B95G	1H Delay Line
C610	ECCF1H470J	C 47pF J 50V	L372	TLK153152	Peaking 15uH
C611	ECCD1H050DC	C 5pF D 50V	L373	TLT470K991K	Peaking 47uH
C612	ECEA1HU2R2	E 2.2uF 50V	L501	TLY25360F	Deflection Yoke
C614	ECKF1H152KB	C 1500pF K 50V	L502	TLH15672P	Linearity Coil
C615	ECEA1HU010	E 1uF 50V	L504	TLT151K991R	Peaking 150uH
C801	ECQU1A333MH	P 0.033uF TypeUL	L505	TLT100K993E	Peaking 10uH
C802	ECQU1A333MH	P 0.033uF TypeUL	L506	TLTAMSKI103K	Choke Coil
C803	ECKDNS472ME	C 4700pF TypeUL	L507	TLP13113E	Choke Coil
C805	ECKD2H103PU7	C 0.01uF P 500V	L601	TLT150K991R	Peaking 15uH
C806	ECKD2H103PU7	C 0.01uF P 500V	L603	TLT222K993G	Peaking 2.2mH
C807	ECKD2H103PU7	C 0.01uF P 500V	L801	ELF18D216	Line Filter
C809	ECET2DR221SW	E 220uF 200V	L802	TLK159025N	Degaussing Coil
C810	ECQM1H104KV	F 0.1uF K 50V	L803	TSC909	Choke Coil
C811	ECEA1HU470	E 47uF 50V	L804	TSC909	Choke Coil
C812	ECEA1HU4R7	E 4.7uF 50V	L805	TSC909	Choke Coil
C813	ECKF1H221KB	C 220pF K 50V	L806	TSC909	Choke Coil
C814	ECKDNS221MB	C 220pF TypeUL	L854	TSC909	Choke Coil
C815	ECKDNS221MB	C 220pF TypeUL	L855	TSC909	Choke Coil
C816	ECKF1H103ZF	C 0.01uF Z 50V	L856	TSC909	Choke Coil
C819	ECEA2GS101	E 100uF 160V	L857	TSC909	Choke Coil
C820	ECEA1EU222	E 220uF 25V	L858	TSC909	Choke Coil
C851	ECEA1VF102X	E 1000uF 35V	L859	TSC909	Choke Coil
C852	ECQM1H823KV	F 0.082uF K 50V	TRANSFORMERS		
C853	ECKF1H103ZF	C 0.01uF Z 50V	T501	TLF14744F	FlyBack Trans.
C854	ECCF1H330J	C 33pF J 50V	T502	TLH15412	H. Drive Trans.
C858	ECEA2GS101	E 100uF 160V	T801	ETS35K403A	Converter Trans.
C859	ECEA1EG221S	E 220uF 25V	T851	TLP15903	Converter Drive
C860	ECEA1EG221S	E 220uF 25V	T852	ETS39K59A	Converter Output
C861	ECKF1H103ZF	C 0.01uF Z 50V	DIODES		
C862	ECKF1H103ZF	C 0.01uF Z 50V	D301	MA165	Diode
C863	ECQM1H472KV	F 4700pF K 50V	D303	MA165	Diode
C864	ECEA1EU3R3	E 3.3uF 25V			
C865	ECKF1H391KB	C 390pF K 50V			
C866	ECKF1H103ZF	C 0.01uF Z 50V			

BT-S1000N

Ref. No.	Part No.	Description	Ref. No.	Part No.	Description
D305	MA165	Diode	D808	TVSES1Z	Diode
D307	MA165	Diode	D809	IN4003	Diode
D308	MA27TB	Diode	D810	TVSRGP10J	Diode
D310	MA165	Diode	D811	ERB44-08	Diode
D314	MA165	Diode	D812	TVSRGP10J	Diode
D315	MA165	Diode	D813	RZKN1	Zener Diode 160V
D316	MA165	Diode	D814	ERPZ4BOM100B	Resistor
D317	MA4056M	Zener Diode 5.6V	D815	LN38GP	LED
D318	MA4056M	Zener Diode 5.6V	D816	TVSRGP10J	Diode
D319	MA165	Diode	D817	P6KE130A	Zener Diode 130V
D401	TVSRD16EB1	Zener Diode 16V	D851	EU2A	Diode
D402	MA165	Diode	D852	TVSRGP10J	Diode
D403	IN4003	Diode	D853	TVSRGP10J	Diode
D404	MA165	Diode	D854	1S5118	Diode
D405	TVSRD24EB1	Zener Diode 24V	D855	TVSRD6.2EB1	Zener Diode 6.2V
D406	MA27T-A	Diode	D856	TVSRD6.2EB1	Zener Diode 6.2V
D407	MA165	Diode	D857	MA165	Diode
D408	MA165	Diode	D858	MA165	Diode
D409	MA165	Diode	D859	MA165	Diode
D501	MA165	Diode	D860	EU2Z	Diode
D503	ES01F	Diode	D861	TVSES1Z	Diode
D504	TVSRGP10J	Diode	TRANSISTORS		
D505	MA167	Diode	Q201	2SC1684-Q.R	Audio Buffer
D506	AL101Z	Diode	Q202	2SC1684-Q.R	Audio Buffer
D507	TVSES1	Diode	Q301	2SC1684-Q.R	Video Buffer
D508	TVSRGP10J	Diode	Q302	2SC1684-Q.R	Video Buffer
D509	MA165	Diode	Q303	2SA564-Q.R	Video Amp & Clamp
D510	TVSRGP10J	Diode	Q304	2SA564-Q.R	Video Buffer
D511	MA27WA	Diode	Q308	2SA564-Q.R	Video Buffer
D512	TVSRD12EBM	Zener Diode 12V	Q351	2SC1473-QNC	Video Out
D514	MA165	Diode	Q352	2SC1473-QNC	Video Out
D515	MA165	Diode	Q353	2SC1473-QNC	Video Out
D516	MA165	Diode	Q371	2SC1684-Q.R	Video Buffer
D517	MA165	Diode	Q372	2SC1684-Q.R	Differential Amp
D518	MA165	Diode	Q373	2SC1684-Q.R	Differential Amp
D520	MA27WA	Diode	Q374	2SC1684-Q.R	Chroma Buffer
D521	ERZC07DK221	Varister	Q375	2SC1684-Q.R	Video Buffer
D523	MA165	Diode	Q379	2SC1684-Q.R	Trap Switch
D524	MA165	Diode	Q380	2SC1684-Q.R	Comb Switch
D801	EM2B	Diode	Q401	2SC1383NC	Vertical Position
D802	EM2B	Diode	Q402	2SA564-Q.R	V-Sync Delay
D803	EM2B	Diode	Q403	2SC1684-Q.R	V-Sync Delay
D804	EM2B	Diode	Q501	2SC1473AH	H. Drive
D805	MA170	Diode			
D806	MA106BL	Zener Diode 6.8V			

Ref. No.	Part No.	Description	Ref. No.	Part No.	Description
Q502	2SB1437-Q	H. Out	S502	ESD32154	Sync Switch
Q503	2SB774-Q.R	Ext Sync Separate	S503	ESB621282	Underscan Switch
Q504	2SC1684-Q.R	X-Ray Protector	S801	EVV808F25B14	Power/Vol Control
Q505	2SC1684-Q.R	Sync Separator	OTHERS		
Q506	2SC1684-Q.R	Sync Inverter		A260BZ31X	Picture Tube
Q507	2SC1684-Q.R	Sync Buffer		EAS65P34D	Speaker
Q508	2SB774-Q.R	Sync Differentiat		EAS65P34S	Speaker
Q509	2SA564-Q.R	H-Sync Delay		ERD25TLO	0 ohm Resistor
Q510	2SD889-Q.R	H-Sync Delay		NO.18K	Mica Sheet/Q502
Q511	2SA564-Q.R	H-Sync Inverter		PAUC35601	Heat Sink/Q801
Q512	2SA564-Q.R	H-Size Control		TBL173303	Rubber Foot
Q513	2SD1266	H-Size Control		TBM1749B	Panasonic Badge
Q514	2SC1684-Q.R	Burst ColorKiller		TBX1353500	Power/Vol Knob
Q515	2SD889-Q.R	Sync Buffer		TBX1353600	Front Cont Knob
Q602	2SA564-Q.R	Burst ColorKiller		TBX2783100	Front Switch Knob
Q603	2SA564-Q.R	Burst ColorKiller		THE391	Foot/SP Mounting
Q801	2SC3872	Converter Out		THN1948-2	Nut/SWB01
Q802	2SA885-R	Converter Drive		THT1004	CRT Mount Screw
Q803	2SD965-Q.R	Current Protector		THW40807-9	Washer/SWB01
Q804	2SC1684-Q.R	Error Detector		THW70033N	Washer/Headphones
Q851	2SC3300A	Converter Output		TJB13611	Terminal Board
Q852	2SC1383NC	Converter Drive		TJC6319	Fuse Holder
I. C				TJS168980	4P Socket/CO-2B
				TJS168990	5P Socket/CO-3A
IC201	AN5265	Audio Out		TJS169070	3P Socket/CO-1L
IC401	AN5436N	H/V Osc. Drive		TJS169071	3P Socket/CO-2L
IC402	AN5515X	V. Out		TJS169410	DC Power Socket
IC501	TVSUPD4503BC	Sync Delay		TJS169680	2P Socket/CO-1B
IC502	L78M12	B+ Regulator		TJS1A4160	BNC Connector
IC601	AN5316N	Chroma/Video		TJS1A5080	CRT Socket
IC851	AN6780	Timer		TJS1A7130	Headphone Jack
IC852	AN6913	ADDP IC		TJS1A8520	2P Socket/CO-5A
IC853	AN5900	Converter Control		TJS1A8520	2P Socket/CO-4A
				TJS1A8570	7P Socket/CO-6A
FILTERS				TJS2A8430	VTR 8P Socket
X371	TAFTPS3.58MJ	3.58MHz Trap		TJS2A8730	RCA Jack
X601	TSS816N2	Crystal		TJT1398	L-Connect/X-1.2.3
SWITCHES				TKA137901	Metal Cabinet
				TKE1312A02	Front Cabinet
S301	ESB621282	Comb/Trap Switch		TKK139208	Handle
S302	ESB621282	Line/VTR Switch		TKK139209-1	Handle Cover
S303	ESB621282	Blue Only Switch		TKP1312791	Rear Panel
S401	EVQR4AL13	Service Switch		TKP1312801	Control Panel
S501	ESB621282	Pulse Cross SW		TKS13329	Bottom Cover

BT-S1000N

Ref. No.	Part No.	Description	Ref. No.	Part No.	Description
	TKU136701-1	Back Cover		XTC3+12AFN	DC Socket Screw
	TKZ138113-1	Mounting Metal (R)		XTV3+8BFZ	Rear Panel Screw
	TKZ138114-1	Mounting Metal (L)		XTV3+8BFZ	Mounting Screw
	TLC2042	Convergence Yoke		XWC4B	Tooth Lock Washer
	TMM13592	Rubber Cushion		XZB75X65C04	Set Cover
	TMM13902	LED Spacer			
	TMM14416	Cord Bushing			
	TMM17538	DY Wedge			
	TMX13402-1	A-Board Clamper			
	TMX13430-1	A-Board Spacer			
	TMX13935	Speaker Bracket			
	TMX13936	Shield Case Hold			
	TNP100306ZA	Circuit Board-B			
	TNP100307CD	Circuit Board-C			
	TNP100308ZA	Circuit Board-D			
	TNP100310ZA	Circuit Board-H			
	TNP100311CD	Circuit Board-L			
	TNP100312ZA	Circuit Board-X			
	TNP190018CD	Circuit Board-A			
	TFC1310701	Packing Case			
	TQB511103	Instruction Bag			
	TSX5125	Power Cord			
	TUC13789	Heat Sink/Q851			
	TUC24557	DY Shield Case			
	TUC27735-1	Heat Sink/IC402			
	TUC37746	Heat Sink/Q502			
	TUW13421	Power/Vol Bracket			
	TUX13276	FBT Support Metal			
	TUX13598	Control Fix Metal			
	TUX14605	B-Board Support			
	TXAJT011030M	Coupler Kit/CO-1L			
	TXAJT021030M	Coupler Kit/CO-2L			
	TXAJT031030M	Coupler Kit/CO-1A			
	TXAJT041000N	Coupler Kit/CO-1B			
	TXAJT051000N	Coupler Kit/CO-3A			
	TXAJT061000N	Coupler Kit/CO-2B			
	TXAPD011030M	Cushion Set			
	TXF3A011030M	CRT Ground Strap			
	TXFHE01811	Mounting Screw			
	TXFTB011030M	Handl Mount Screw			
	XBA1F30NU100	Fuse 125V-3A/FB01			
	XBA1F80NU100	Fuse 125V-8A/FB51			
	XNGT3009N	Nut/Headphones			
	XSB4+8S	Grounding Screw			
	XTB4+12AFZ	Termi Mount Screw			